



# ST17H63

## Bluetooth Low Energy (BLE) System on Chip with SIG-Mesh

### Key Features

- ARM® Cortex™-M0 32-bit processor
- Memory
  - 512KB/2MB in-system flash memory
  - 128KB ROM
  - 138KB SRAM, all programmable retention in sleep mode
  - 8-channel DMA
- 33/19 general purpose I/O pins
  - All pins can be configured as serial interface and programmable IO MUX function mapping
  - All pins can be configured for wake-up
  - 18 pins for triggering interrupt
  - 3 quadrature decoder(QDEC)
  - 6-channel PWM
  - 4-channel I2S
  - 2-channel PDM
  - 2-channel I2C
  - 2-channel SPI
  - 1-channel UART
  - JTAG
- DMIC/AMIC with microphone bias
- 8-channel 12bit ADC with low noise voice PGA
- 4-channel 24bit timer, one watchdog timer
- Real timer counter (RTC)
- Power, clock, reset controller
- Flexible power management
  - Supply voltage range 1.8V to 3.6V
  - Embedded buck DC-DC and LDOs
  - Battery monitor: Supports low battery detection
- Power consumption
  - 0.7µA @ OFF Mode (IO wake up only)
  - 2µA @ Sleep Mode with 32KHz RTC
  - Receiver: 6.7mA @sensitivity level
  - Transmitter: 6.7mA @0dBm TX power
- RC oscillator hardware calibrations
  - 32KHz RC osc for RTC with +/-500ppm accuracy
  - 32MHz RC osc for HCLK with 3% accuracy
- High Speed Throughput
  - Support BLE 2Mbps Protocol
  - Support Data Length Extension
  - Throughput up to 1.6Mbps(DLE+2Mbps)
- Support SIG-Mesh Multi-Feature
  - Friend Node
  - Low Power Node
  - Proxy Node
  - Relay Node
- 2.4 GHz transceiver
  - Compliant to Bluetooth 5.2
  - Sensitivity:
    - 97dBm@BLE 1Mbps data rate
    - 103dBm@BLE 125Kbps data rate
  - TX Power -20 to +10dBm in 3dB steps
  - Single-pin antenna: no RF matching or RX/TX switching required
  - RSSI (1dB resolution)
- AES-128 encryption hardware
- Link layer hardware
  - Automatic packet assembly
  - Automatic packet detection and validation
  - Auto Re-transmit
  - Auto ACK
  - Hardware Address Matching
  - Random number generator
- Operating temperature: -40 °C~125°C
- RoHS Package: QFN48
- Applications: wearables, beacons, appliances, home and building, health and medical, sports and fitness, industrial and manufacturing, retail and payment, security, data transmission, remote control, PC/mobile/TV peripherals, internet of things (IoT)

## Liability Disclaimer

Shenzhen Lenze technology Co.,LTD reserves the right to make changes without further notice to the product to improve reliability, function or design. Shenzhen Lenze technology Co.,LTD does not assume any liability arising out of the application or use of any product or circuits described herein.

## Life Support Applications

Shenzhen Lenze technology Co.,LTD's products are not designed for use in life support appliances, devices, or systems where malfunction of these products can reasonably be expected to result in personal injury. Shenzhen Lenze technology Co.,LTD customers using or selling these products for use in such applications do so at their own risk and agree to fully indemnify Shenzhen Lenze technology Co.,LTD for any damages resulting from such improper use or sale.

## Contact Details

For your nearest dealer, please see [www.Lenzeinc.com](http://www.Lenzeinc.com).

Information regarding product updates, downloads, and technical support can be accessed through our homepage.

## Main Office

### Shenzhen

7th Floor,Ching Po Building,Shenzhen Special Zone Press

Group,Futian District,Shenzhen

Phone: +86 755-8203-1775

Email: [info@lenzotech.com](mailto:info@lenzotech.com)

## Revision History

Date	Version	Description
2018.05	1.0	
2019.06	1.1	Added "GPIO DC Characteristics"
2019.07	1.1	1. Added "Power consumption" in the home page 2. Added information about accuracy of RC osc in the home page
2019.08	1.2	Added "DMIC/AMIC Data Path"
2019.10	1.3	1. Updated the information of "Ordering information" 2. Updated the information of "in-system flash memory" and "Power consumption"

# Table of Contents

<b>1</b>	<b>Introduction .....</b>	<b>1</b>
<b>2</b>	<b>Product Overview.....</b>	<b>2</b>
2.1	Block Diagram .....	2
2.2	Pin Assignments and Functions.....	3
2.2.1	ST17H63 (QFN48).....	3
2.2.1.1	Pin Assignment.....	3
2.2.1.2	Pin Function.....	4
<b>3</b>	<b>System Blocks .....</b>	<b>6</b>
3.1	CPU.....	6
3.2	Memory.....	6
3.2.1	ROM .....	8
3.2.2	SRAM.....	8
3.2.3	FLASH .....	8
3.2.4	Memory Address Mapping.....	8
3.3	Boot and Execution Modes .....	9
3.3.1	Mirror Mode.....	9
3.3.2	FLASH Mode.....	9
3.3.3	Boot loader.....	9
3.4	Power, Clock and Reset (PCR) .....	10
3.5	Power Management (POWER) .....	10
3.6	Low Power Features.....	12
3.6.1	Operation and Sleep States.....	12
3.6.1.1	Normal State .....	12
3.6.1.2	Clock Gate State .....	12
3.6.1.3	System Sleep State .....	12
3.6.1.4	System Off State .....	12
3.6.2	State Transition .....	12
3.6.2.1	Entering Clock Gate State and Wake-up.....	12
3.6.2.2	Entering Sleep/off States and Wake-up.....	12
3.7	Interrupts .....	13
3.8	Clock Management (CLOCK).....	14
3.9	IOMUX.....	15
3.9.1	Register table .....	18
3.9.2	Register table .....	21
3.10	GPIO .....	26
3.10.1	Register table .....	28
3.10.1	DC Characteristics.....	31
<b>4</b>	<b>Peripheral Blocks.....</b>	<b>31</b>
4.1	2.4GHz Radio .....	31
4.2	Timer/Counters (TIMER) .....	32
4.2.1	Register table .....	32
4.3	Real Time Counter (RTC) .....	35
4.3.1	Register table .....	35
4.4	AES-ECB Encryption (ECB) .....	37
4.4.1	Register table .....	37

4.5	Random Number Generator (RNG) .....	38
4.6	Watchdog Timer (WDT).....	38
4.7	SPI (SPI) .....	39
4.8	I2C (I2c0, I2c1 Two Independent Instances) .....	39
4.9	I2S.....	39
4.10	UART (UART) .....	39
4.11	DMIC/AMIC Data Path.....	39
4.11.1	Filter Chain Design .....	40
4.11.2	Auto Mute Process .....	40
4.11.3	Digital Gain Control .....	41
4.11.4	Voice Compression .....	41
4.12	Pulse Width Modulation (PWM) .....	41
4.12.1	Register table .....	42
4.13	Quadrature Decoder (QDEC).....	48
4.13.1	Register table .....	48
4.14	Key Scan (KSCAN) .....	51
4.14.1	Register table .....	51
4.15	Analog to Digital Converter (ADC) with Programmable Gain Amplifier (PGA).....	53
4.15.1	PGA Path .....	53
4.15.2	ADC Path .....	54
4.15.3	ADC Channel <3:0> Connectivity.....	56
<b>5</b>	<b>Absolute Maximum Ratings.....</b>	<b>58</b>
<b>6</b>	<b>Operating Conditions .....</b>	<b>59</b>
<b>7</b>	<b>Radio Transceiver .....</b>	<b>60</b>
7.1	Radio Current Consumption.....	60
7.2	Transmitter Specification .....	60
7.3	Receiver Specification .....	60
7.3.1	RX BLE 1Mbps GFSK.....	60
7.3.2	RX BLE 2Mbps GFSK.....	61
7.3.3	RX 500Kbps GFSK.....	62
7.3.4	RX 125Kbps GFSK.....	62
7.4	RSSI Specifications.....	63
<b>8</b>	<b>Glossary .....</b>	<b>64</b>
<b>9</b>	<b>Ordering information .....</b>	<b>65</b>
<b>10</b>	<b>Chip Marking.....</b>	<b>错误!未定义书签。</b>
<b>11</b>	<b>Package dimensions .....</b>	<b>66</b>
11.1	QFN48 package dimensions: .....	66
<b>12</b>	<b>Sample Application and Layout Guide .....</b>	<b>66</b>
12.1	Layout Guide .....	66
12.1.1	Placement .....	66
12.1.2	Bypass Capacitor .....	66
12.1.3	Layer Definition .....	67
12.1.4	Reference clock and trace .....	67
12.1.5	Power line or plane .....	67
12.1.6	Ground Via .....	67

# 1 Introduction

ST17H63 is a System on Chip (SoC) for Bluetooth® low energy applications. ST17H63 has 32-bit ARM® Cortex™-M0 CPU with 138KSRAM/Retention SRAM and an ultra-low power, high performance, multi-mode radio. ST17H63 can support BLE with security, application and over-the-air download update. Serial peripheral IO and integrated application IP enables customer product to be built with minimum bill-of-material (BOM) cost.

## 2 Product Overview

### 2.1 Block Diagram

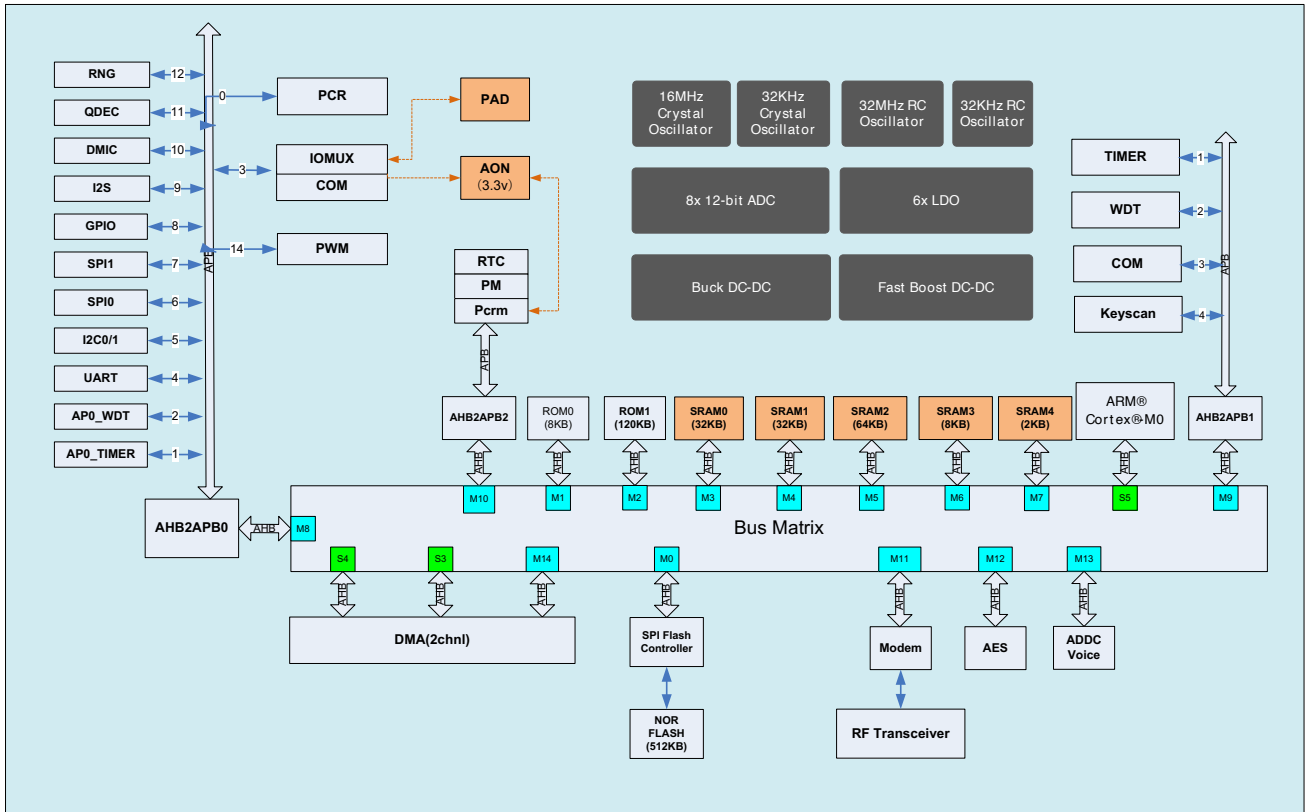

Figure 1: ST17H63 block diagram

## 2.2 Pin Assignments and Functions

This section describes the pin assignment and the pin functions for the different package types.

### 2.2.1 ST17H63 (QFN48)

#### 2.2.1.1 Pin Assignment

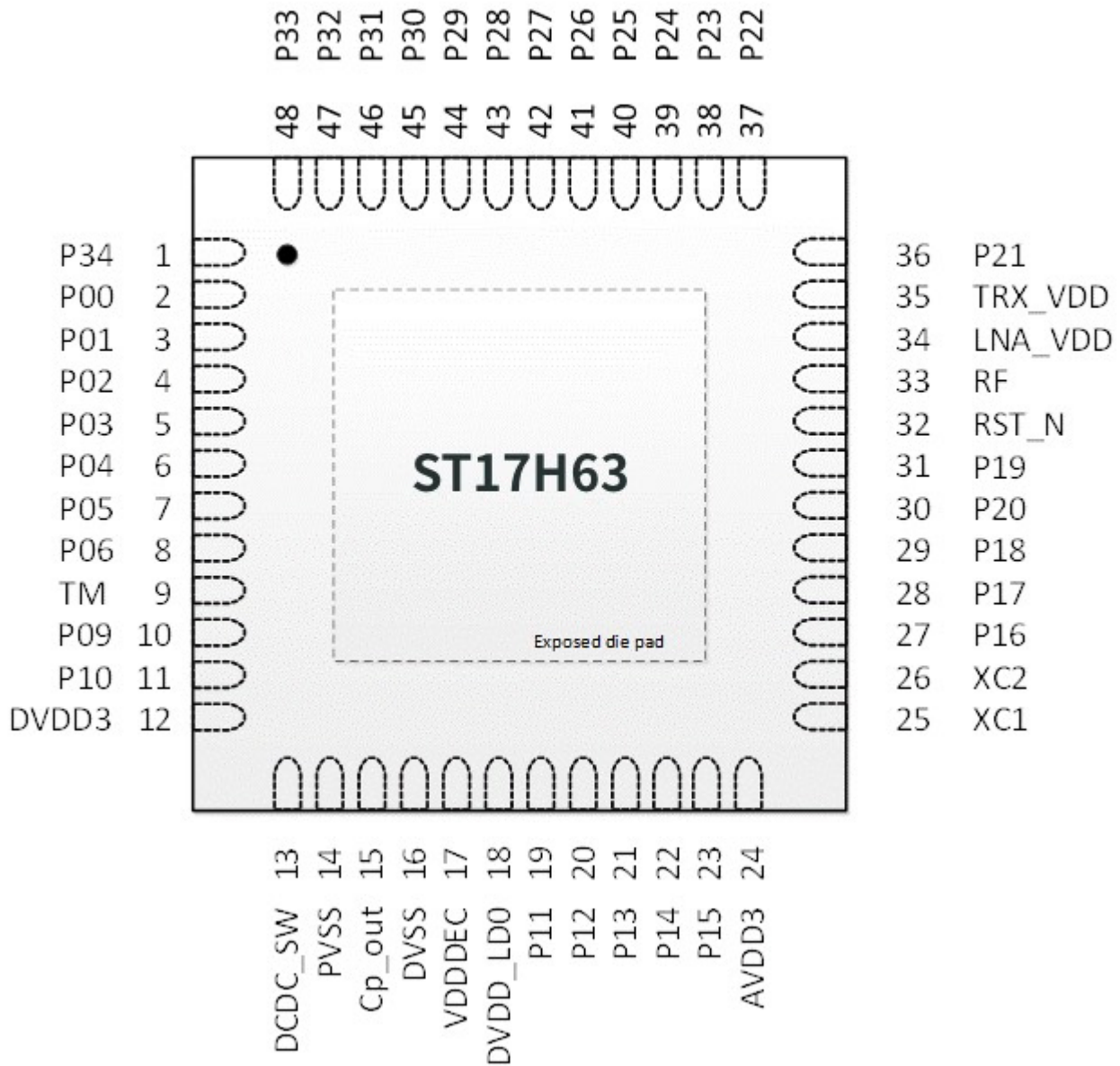

Figure 2: Pin assignment - ST17H63 QFN48 package



## 2.2.1.2 Pin Function

Pin	Pin name	Description
1	P34	all functions configurable *Note: Not support interrupt and ADC function
2	P00	all functions configurable/ JTAG_TDO *Note: Not support ADC function
3	P01	all functions configurable/ JTAG_TDI *Note: Not support ADC function
4	P02	all functions configurable/JTAG_TMS *Note: Not support ADC function
5	P03	all functions configurable/JTAG_TCK *Note: Not support ADC function
6	P04	all functions configurable *Note: Not support ADC function
7	P05	all functions configurable *Note: Not support ADC function
8	P06	all functions configurable *Note: Not support ADC function
9	TM	Test_Mode
10	P09	all functions configurable *Note: Not support ADC function
11	P10	all functions configurable *Note: Not support ADC function
12	DVDD3	3V power supply for digital IO, DCDC, Charge pump
13	DCDC_SW	Buck dcdc output
14	PVSS	Buck dcdc and charge pump power vss
15	cp_out	charge pump output
16	DVSS	digital vss
17	VDDDEC	1.2V VDD_CORE, digital LDO output
18	DVDD_LDO	digital LDO input
19	P11	all functions configurable/AIO<0>
20	P12	all functions configurable/AIO<1>
21	P13	all functions configurable/AIO<2>
22	P14	all functions configurable/AIO<3>
23	P15	all functions configurable/AIO<4>
24	AVDD3	3V power supply for analog IO, bg, rcosc, etc
25	XC1	16M crystal input
26	XC2	16M crystal output
27	P16	all functions configurable/AIO<5>/32K crystal input
28	P17	all functions configurable/AIO<6>/32k crystal output

29	P18	all functions configurable/AIO<7>/PGA differential positive input *Note: Not support interrupt function
30	P20	all functions configurable/AIO<9>/Micphone bias output *Note: Not support interrupt function
31	P19	all functions configurable/AIO<8>/PGA differential negative input *Note: Not support interrupt function
32	RST_N	reset pin
33	RF	RF antenna
34	LNA_VDD	LNA_VDD
35	TRX_VDD	TRX_VDD
36	P21	all functions configurable *Note: Not support interrupt function and ADC function
37	P22	all functions configurable *Note: Not support interrupt function and ADC function
38	P23	all functions configurable *Note: Not support interrupt function and ADC function
39	P24	all functions configurable/test_mode_select[0] *Note: Not support interrupt function and ADC function
40	P25	all functions configurable/test_mode_select[1] *Note: Not support interrupt function and ADC function
41	P26	all functions configurable *Note: Not support interrupt function and ADC function
42	P27	all functions configurable *Note: Not support interrupt function and ADC function
43	P28	all functions configurable *Note: Not support interrupt function and ADC function
44	P29	all functions configurable *Note: Not support interrupt function and ADC function
45	P30	all functions configurable *Note: Not support interrupt function and ADC function
46	P31	all functions configurable *Note: Not support interrupt function and ADC function
47	P32	all functions configurable *Note: Not support interrupt function and ADC function
48	P33	all functions configurable *Note: Not support interrupt function and ADC function

**Table 1: Pin functions ST17H63 QFN48 package**

## 3 System Blocks

The system block diagram of ST17H63 is shown in **Figure 1**.

### 3.1 CPU

The ST17H63 has an ARM Cortex-M0 CPU. The CPU, memories, and all peripherals are connected by AMBA bus fabrics.

The ARM® Cortex™-M0 CPU has a 16-bit instruction set with 32-bit extensions (Thumb-2® technology) that delivers high-density code with a small-memory-footprint. By using a single-cycle 32-bit multiplier, a 3-stage pipeline and a Nested Vector Interrupt Controller (NVIC), the ARM Cortex™-M0 CPU makes program execution simple and highly efficient.

The CPU will play controller role in BLE modem and run all user applications. The following main features are listed below.

- Up to 48Mhz ARM Cortex™-M0 processor core.
  - Low gate count and high energy efficient.
  - ARMv6M architecture, Thumb ISA but no ARM ISA.
  - No cache and no TCM.
  - Up to 32 interrupts embedded NVIC.
  - SysTick timer.
  - Sleep/deep sleep mode.
  - Support low power WFI and WFE
- 4 32-bit general purpose timers and 1 watchdog timer (WDT).
- 120KB ROM for boot and protocol stack.
- 138KB retention SRAM for program and data.
- AHB to APB Bridge for peripherals and registers.
- Clock and reset controller.
- AHB debug access port interface and DAP ROM.
- APB interface to/from BLE modem.
- Dynamic and static clock gating to save power.
- No TRACE.

Some of these features are shared with the AP subsystem.

### 3.2 Memory

ST17H63 has total 128KB ROM, 138KB SRAM and up to 512KB FLASH. The physical address space of these memories is shown in **Figure4**.

## ST17H63 Memory Space

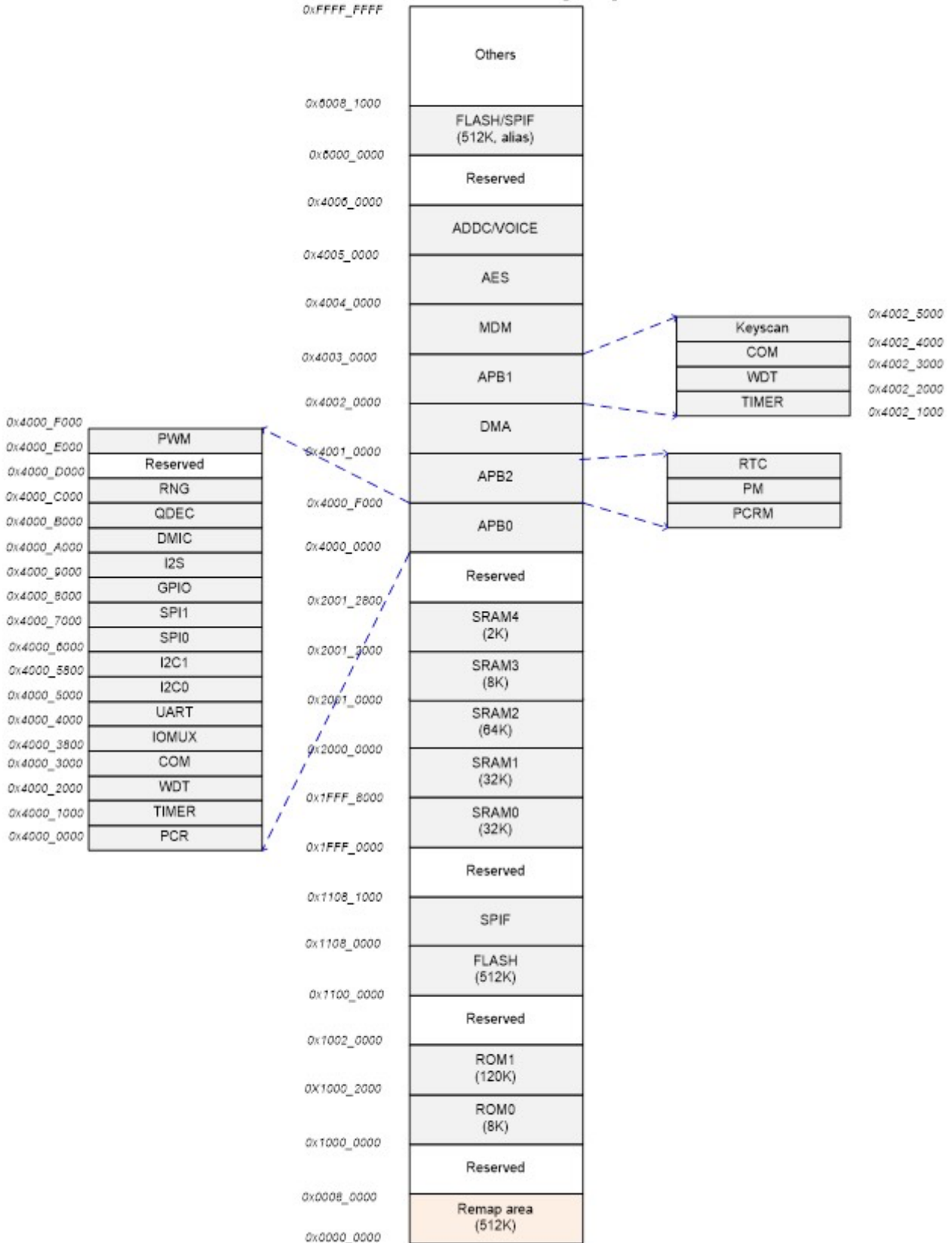

Figure 3: ST17H63 memory space

### 3.2.1 ROM

ST17H63 has 2 ROMs.

	SIZE	CONTENT
ROM0	8KB	Reserved
ROM1	120KB	Boot ROM for M0. Protocol stack. Common peripheral drivers.

**Table 2: List of ROMs**

### 3.2.2 SRAM

ST17H63 has 5 SRAM blocks. All 5 SRAM blocks have retention capability, which can be configured individually. All SRAM blocks can be used to store program or data.

	SIZE	CONTENT
SRAM0	32KB	
SRAM1	32KB	
SRAM2	64KB	
SRAM3	8KB	
SRAM4	2KB	

**Table 3: List of SRAMs**

### 3.2.3 FLASH

ST17H63 has FLASH to provide non-volatile program and data storage. The size of the FLASH can be 256KB or 2MB. ST17H63 supports 2-wire reading.

### 3.2.4 Memory Address Mapping

Name	Size (KB)	Master	Physical Address	CM4 Alias	M0 Remap		
					0	1	2
ROM0	8	M0	1000_0000~1000_1FFF	0x0			
ROM1	120	M0	1000_2000~1001_FFFF		0x0		
RAM0	32	M0	1FFF_0000~1FFF_7FFF				
RAM1	32	M0	1FFF_8000~1FFF_FFFF				
RAM2	64	M0	2000_0000~2000_FFFF			0x0	
RAM3	8	M0	2001_0000~2001_1FFF				
RAM4	2	M0	2001_2000~2001_27FF				
FLASH	512	M0	1100_0000~1107_FFFF				0x0
			6000_0000~6007_FFFF				

**Table 4: Memory address mapping**

### 3.3 Boot and Execution Modes

During the boot, the ROM1 is aliased to 0x0 address. The M0 starts to execute the program from the ROM1.

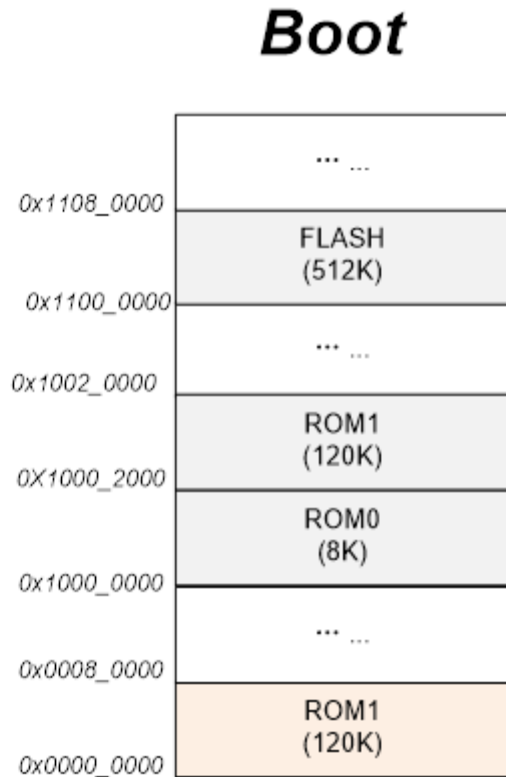

Figure 4: ST17H63 boot mode

#### 3.3.1 Mirror Mode

The mirror mode is not tied to the chip variations. Any chip variation can use mirror mode to execute program. In the mirror mode, the program is copied from the FLASH to the SRAM, then is executed in the SRAM. For the M0 processor, one of the SRAM blocks must be aliased to 0x0 address.

#### 3.3.2 FLASH Mode

The FLASH mode is not tied to the chip variations. Any chip variation can use FLASH mode to execute program. In the FLASH mode, the program is executed in the FLASH. For the M0 processor, the FLASH must be aliased to 0x0 address.

#### 3.3.3 Boot loader

The boot loader in the ROM has the basic structure as shown below. The content in the FLASH should be specifically defined to allow boot loader to identify whether the FLASH content is valid, as shown in the example below. If the FLASH is valid, the ROM boot loader will put the chip in the normal mode and start normal program execution. If the FLASH is not valid, the boot loader will enter FLASH programming mode.

Address	Variable	Content
0	PRODUCT_MODE	Identify the chip mode
4	CODE_BASE	The base address of the code

8	CODE_LEN	The length of the code
C	BOOT_MODE	Identify mirror or FLASH mode

**Table 5: Flash content example**

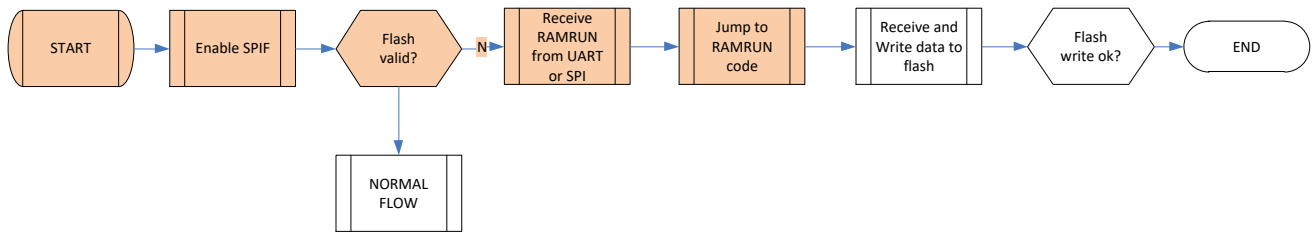

**Figure 5: Bootloader flow**

### 3.4 Power, Clock and Reset (PCR)

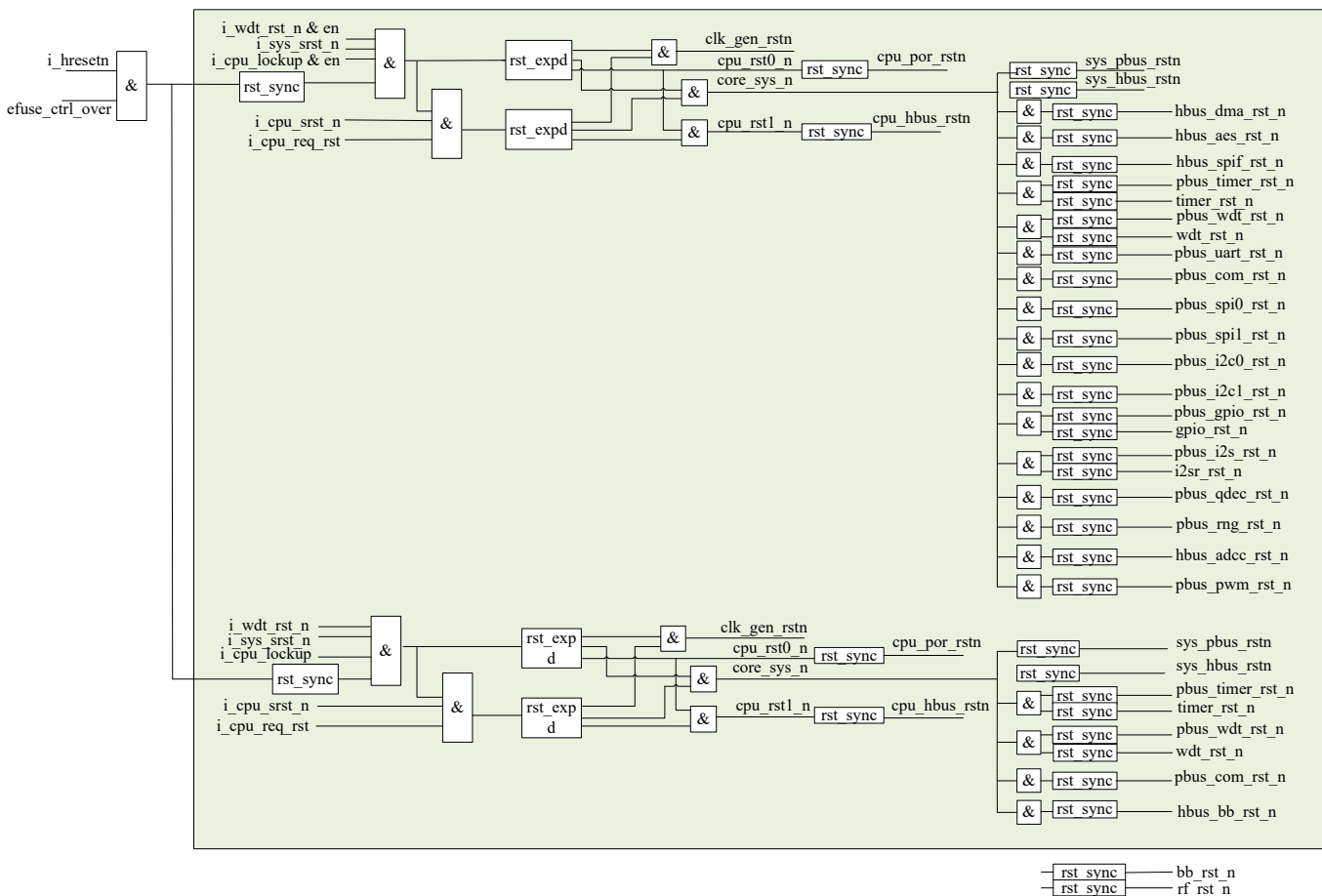

**Figure 6: ST17H63 power, clock and reset**

### 3.5 Power Management (POWER)

The power management system is highly flexible with functional blocks such as the CPU, radio transceiver, and peripherals saving separate power state control in addition to the System Sleep mode and OFF modes. When in System Normal mode, all functional blocks will independently be turned on depending on needed application functionality.

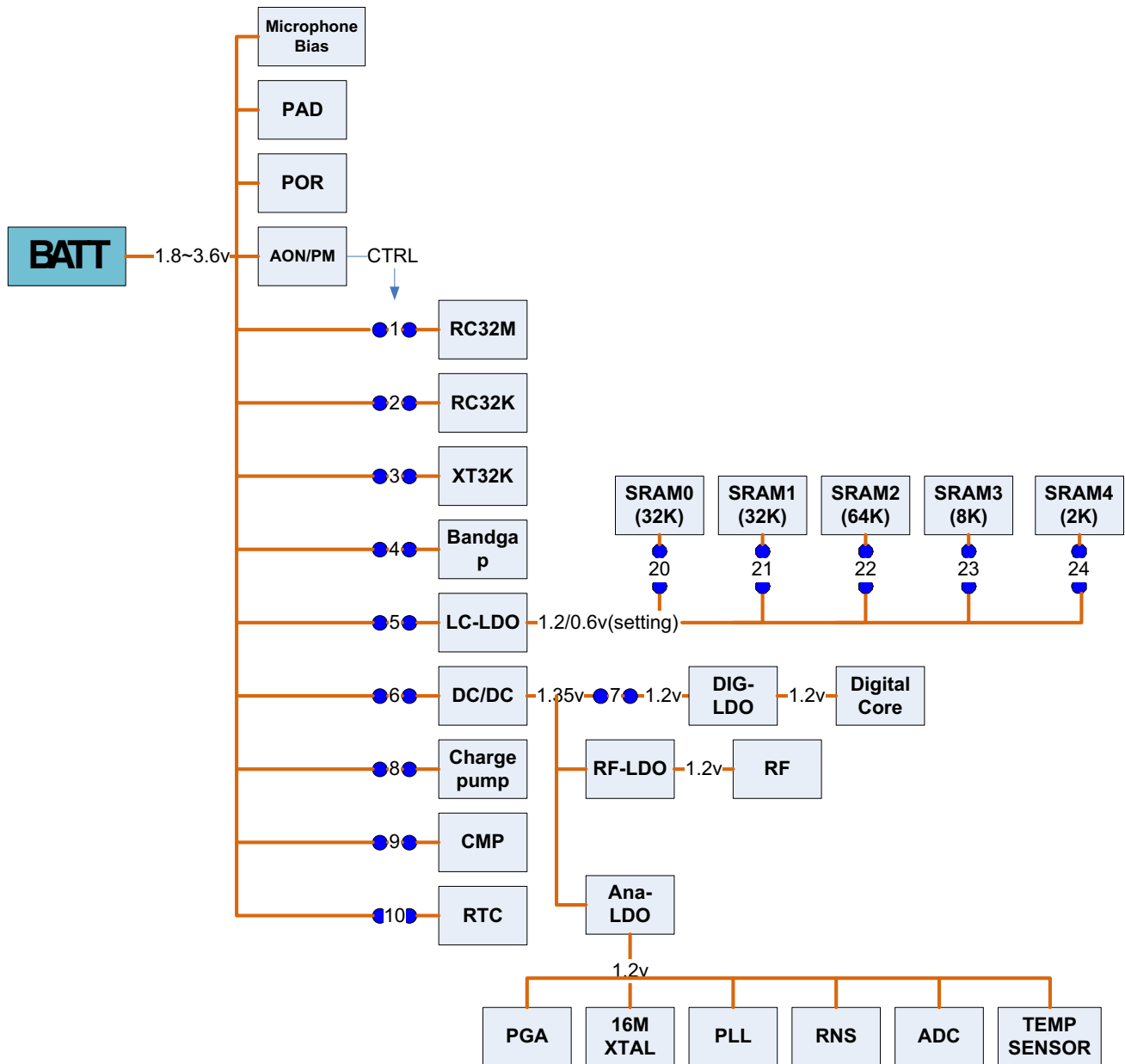

Figure 7: Power system

The following diagram is Normal, Sleep and Off mode. Switches are optional depending on user's request.

Switch	Normal	Sleep	Off
1RC32M	On	Off	Off
2RC32K	On	Optional	Off
3XT32K	On	Optional	Off
4bandgap	On	Off	Off
5LC-LDO	On	on	Off
6DC/DC	On	Off	Off
7DIG-LDO	On	Off	Off



8charge pump	On	Off	Off
9CMP	On	Optional	Off
10RTC	On	Optional	Off
20SRAM-32K	1.2v	0.6v	0
21SRAM-32K	1.2v	0.6v	0
22SRAM-64K	1.2v	0.6v	0
23SRAM-8K	1.2v	0.6v	0
24SRAM-2K	1.2v	0.6v	0

**Table 6: Flash Switches of different power modes**

## 3.6 Low Power Features

### 3.6.1 Operation and Sleep States

#### 3.6.1.1 Normal State

#### 3.6.1.2 Clock Gate State

The CPU executes WFI/WFE to enter clock gate state. After wake-up from clock-gate state, the CPU continues to execute the program from where it stopped. The wake-up sources includes interrupts and events. The wake-up sources are configured by the software according to applications.

#### 3.6.1.3 System Sleep State

The wake-up sources include:

- IO
- RTC
- RESET
- UVLO reset

#### 3.6.1.4 System Off State

The wake-up sources include:

- IOs
- RESET
- UVLO reset

## 3.6.2 State Transition

### 3.6.2.1 Entering Clock Gate State and Wake-up

CPU executes WFI/WFE.

### 3.6.2.2 Entering Sleep/off States and Wake-up

The PM registers identify whether the CPU is in mirror mode or FLASH mode before sleep or off, and record the remap and vectors. The CPU configures the corresponding PM registers to put the chip into sleep or off mode. After wake-up, the chip enters boot mode to execute boot code in the ROM. The ROM code checks the mode before sleep/off and the remap information, perform corresponding configurations, and starts to execute the program.

### 3.7 Interrupts

Interrupt Name	M0 Interrupt Number
Reserved	0
Reserved	1
cp_timer_irq	2
cp_wdt_irq	3
bb_irq	4
kscan_irq	5
rtc_irq	6
Reserved	7
Reserved	8
timer_irq	9
wdt_irq	10
uart_irq	11
i2c0_irq	12
i2c1_irq	13
spi0_irq	14
spi1_irq	15
gpio_irq	16
i2s_irq	17
spif_irq	18
dmac_intr	19
dmac_inttc	20
dmac_interr	21
fpidc	22
fpdzc	23
fpioc	24
fpufc	25
fpofc	26
fpixc	27
aes_irq	28
adcc_irq	29
qdec_irq	30
rng_irq	31

**Table 7: Interrupts**

### 3.8 Clock Management (CLOCK)

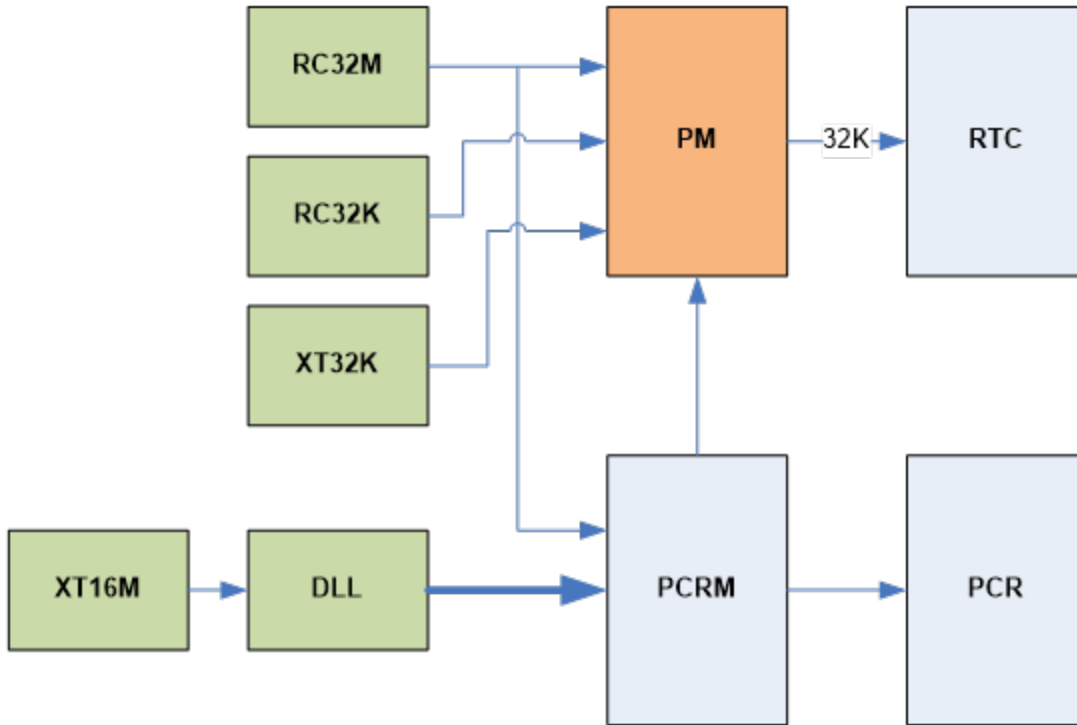

**Figure 8: Clock management**

There are two crystal clock sources: 16MHz crystal oscillator (XT16M) and 32.768kHz crystal oscillator (XT32k), of which the 32.768k crystal oscillator is optional. There are also two on chip RC oscillators: 32MHz RC oscillator (RC32M) and 32kHz RC oscillator (RC32k), both of which can be calibrated with respect to 16MHz crystal oscillator. If 32.768kHz crystal is not installed, RC32k oscillator would be periodically calibrated and used for RTC. At initial power up or wake up before XT16M oscillator starts up, RC32M is used as the main clock. An on-chip DLL generates higher frequency clocks such as 32/48/64/96MHz from the XT16M clock source.

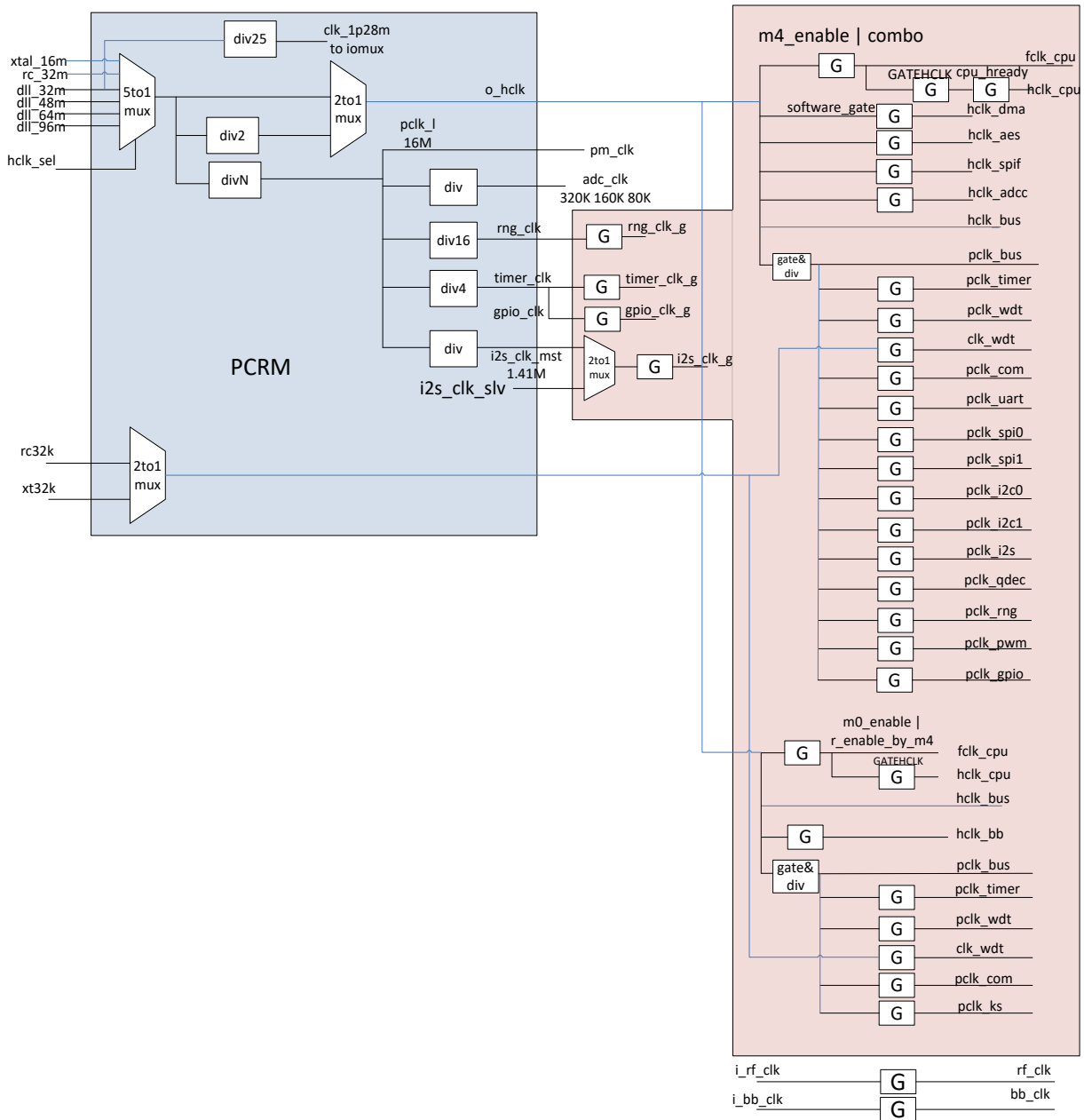
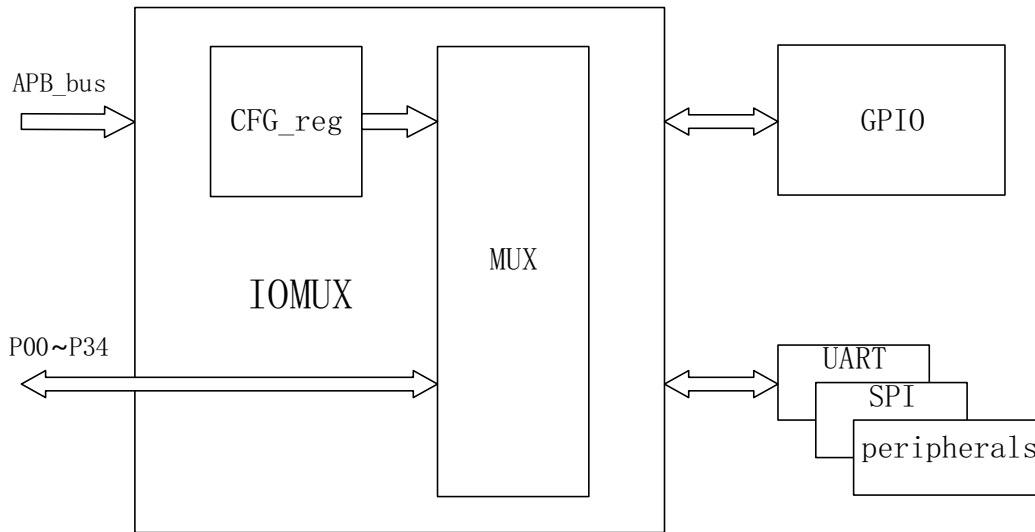

Figure 9: Clock structure diagram

### 3.9 IOMUX

The IOMUX provides a flexible I/O configuration, as the ports of most of the peripherals can be configured and mapped to any of the physical I/O pads (I/O at die boundary). These peripheral modules include I2C 0-1, I2S, UART, PWM 0-5, SPI 0-1, Quadrature Decoder etc. However for other specific purpose peripherals, their IOs mappings are fixed when they are enabled. These specific purpose peripherals include JTAG, analog\_ios, GPIOs and key scan.

Figure 11 below shows the IOMUX functional diagram.



**Figure 10: IOMUX structure diagram**

There are 33 configurable pads which are from P00 to P07 and from P09 to P34. P08 pad is assigned for TM pin which is a test mode pin. The table below shows the mapping of the peripheral IOs that can be mapped through IOMUX. These include I2C 0-1, I2S, UART, PWM 0-5, SPI 0-1, Quadrature Decoder, 1.28MHz clock and dmic\_out.

Signal Name	IO	FULLMUX
iic0_scl	B	0
iic0_sda	B	1
iic1_scl	B	2
iic1_sda	B	3
i2s_sck	B	4
i2s_ws	B	5
i2s_sdo0	O	6
i2s_sdo1	O	35
i2s_sdo2	O	36
i2s_sdo3	O	37
i2s_sdi0	I	7
i2s_sdi1	I	38
i2s_sdi2	I	39
i2s_sdi3	I	40
uart_tx	O	8
uart_rx	I	9
pwm0	O	10
pwm1	O	11
pwm2	O	12
pwm3	O	13
pwm4	O	14
pwm5	O	15
spi_0_sck	B	16
spi_0_ssn	B	17

spi_0_tx	O	18
spi_0_rx	I	19
spi_1_sck	B	20
spi_1_ssn	B	21
spi_1_tx	O	22
spi_1_rx	I	23
chax	I	24
chbx	I	25
chix	I	26
chay	I	27
chby	I	28
chiy	I	29
chaz	I	30
chbz	I	31
chiz	I	32
clk_1p28m	O	33
adcc_dmic_out	I	34

**Table 8: Peripheral IO mapped through IOMUX**

On the other hand, there are also special purpose peripherals, whose IOs are fixed to certain physical pads, when these peripheral functions are enabled. These special purpose peripherals include: JTAG, analog I/Os (ADC inputs), GPIO, and key scan. When they are enabled, their IOs are mapped to physical pads according to the following table (by default JTAG is enabled).

QFN48	QFN32				Name
0	√	GPIO_P00	jtag_dout	GPIO	mk_in[0]
1	√	GPIO_P01	jtag_din	GPIO	mk_out[0]
2	√	GPIO_P02	jtag_tm	GPIO	mk_in[1]
3	√	GPIO_P03	jtag_clk	GPIO	mk_out[1]
4		GPIO_P04	GPIO		mk_out[9]
5		GPIO_P05	GPIO		mk_in[10]
6		GPIO_P06	GPIO		mk_out[10]
7		GPIO_P07	GPIO		mk_in[11]
8	√	TEST_MODE			
9	√	GPIO_P09	GPIO		mk_out[4]
10	√	GPIO_P10	GPIO		mk_in[4]
11		GPIO_P11	GPIO	analog_io[0]	mk_out[11]
12		GPIO_P12	GPIO	analog_io[1]	mk_in[12]
13		GPIO_P13	GPIO	analog_io[2]	mk_out[12]
14	√	GPIO_P14	GPIO	analog_io[3]	mk_out[2]
15	√	GPIO_P15	GPIO	analog_io[4]	mk_in[2]
16	√	GPIO_P16	XTALI(ANA)	GPIO	mk_out[16]
17	√	GPIO_P17	XTALO(ANA)	GPIO	mk_out[17]
18	√	GPIO_P18	GPIO	analog_io[7]	mk_in[5]
19		GPIO_P19	GPIO	analog_io[8]	mk_in[13]
20	√	GPIO_P20	GPIO	analog_io[9]	mk_out[5]
21		GPIO_P21	GPIO		mk_out[13]

22		GPIO_P22	GPIO		mk_in[14]
23	√	GPIO_P23	GPIO		mk_in[6]
24	√	GPIO_P24	GPIO		mk_out[3]
25	√	GPIO_P25	GPIO		mk_in[3]
26		GPIO_P26	GPIO		mk_out[14]
27		GPIO_P27	GPIO		mk_in[9]
28		GPIO_P28	GPIO		mk_out[8]
29		GPIO_P29	GPIO		mk_in[15]
30		GPIO_P30	GPIO		mk_out[15]
31	√	GPIO_P31	spi_t_ssn	GPIO	mk_out[7]
32	√	GPIO_P32	spi_t_rx	GPIO	mk_in[7]
33	√	GPIO_P33	spi_t_tx	GPIO	mk_out[6]
34	√	GPIO_P34	spi_t_sck	GPIO	mk_in[8]

**Table 9: Peripheral IO mapped through IOMUX (special purpose)**

In the IOMUX table above, the first column is the IO pad mapping in default mode, when no IOMUX function is selected and no special purpose peripherals such as analog IO, GPIO<0:3>, key scan, are enabled. In this mode, pin<0:3> are used for JTAG.

When analog IOs are enabled, pins<11:15>, <18:20> are connected to internal analog IOs. More specifically, analog\_io<0:4><9> are connected to ADC inputs, analog\_io<7,8> are connected to PGA inputs.

In JTAG mode, data output for JTAG test mode is mapped to P00; data input for JTAG test mode is mapped to P01; mode control input for JTAG test mode is mapped to P02; clock input for JTAG test mode is mapped to P03.

### 3.9.1 Register table

Detailed IOMUX register table and physical IO pad control are shown below.

Base address: 4000\_3800

OFFSET	TYPE	RESET	NAME	DESCRIPTION
<b>0x0</b>			<b>r_analog_io</b>	
[31:10]	RW	22'h0	reserved	
[9:0]	RW	10'h60	r_analog_io_en	Analog IO enable
<b>0xc</b>			<b>full_mux0</b>	<b>register description</b>
[31:0]	RW	32'h0	r_func_io_en[31:0]	full mux enable. [8] must set to 0
<b>0x10</b>			<b>full_mux1</b>	<b>register description</b>
[31:3]	RW	29'h0	reserved	
[2:0]	RW	3'h0	r_func_io_en[34:32]	full mux enable
<b>0x14</b>			<b>gpio_papb</b>	<b>register description</b>
[31:17]	RW	15'h0	reserved	
[16]	RW	1'h0	r_gpio_pb_16_en	gpio_16 enable
[15]	RW	1'h0	r_gpio_pb_15_en	gpio_15 enable

[14]	RW	1'h0	r_gpio_pb_14_en	gpio_14 enable
[13]	RW	1'h0	r_gpio_pb_13_en	gpio_13 enable
[12:4]	RW	9'h0	reserved	
[3]	RW	1'h0	r_gpio_pa_03_en	gpio_03 enable
[2]	RW	1'h0	r_gpio_pa_02_en	gpio_02 enable
[1]	RW	1'h0	r_gpio_pa_01_en	gpio_01 enable
[0]	RW	1'h0	r_gpio_pa_00_en	gpio_00 enable
<b>0x18</b>			<b>func_io0</b>	<b>register description</b>
[31:30]	RW	2'h0	reserved	
[29:24]	RW	6'h0	r_func_io03_sel	pad 3 full mux function select
[23:22]	RW	2'h0	reserved	
[21:16]	RW	6'h0	r_func_io02_sel	pad 2 full mux function select
[15:14]	RW	2'h0	reserved	
[13:8]	RW	6'h0	r_func_io01_sel	pad 1 full mux function select
[7:6]	RW	2'h0	reserved	
[5:0]	RW	6'h0	r_func_io00_sel	pad 0 full mux function select
<b>0x1c</b>			<b>func_io1</b>	<b>register description</b>
[31:30]	RW	2'h0	reserved	
[29:24]	RW	6'h0	r_func_io07_sel	pad 7 full mux function select
[23:22]	RW	2'h0	reserved	
[21:16]	RW	6'h0	r_func_io06_sel	pad 6 full mux function select
[15:14]	RW	2'h0	reserved	
[13:8]	RW	6'h0	r_func_io05_sel	pad 5 full mux function select
[7:6]	RW	2'h0	reserved	
[5:0]	RW	6'h0	r_func_io04_sel	pad 4 full mux function select
<b>0x20</b>			<b>func_io2</b>	<b>register description</b>
[31:30]	RW	2'h0	reserved	
[29:24]	RW	6'h0	r_func_io11_sel	pad 11 full mux function select
[23:22]	RW	2'h0	reserved	
[21:16]	RW	6'h0	r_func_io10_sel	pad 10 full mux function select
[15:14]	RW	2'h0	reserved	
[13:8]	RW	6'h0	r_func_io09_sel	pad 9 full mux function select
[7:6]	RW	2'h0	reserved	
[5:0]	RW	6'h0	r_func_io08_sel	pad 8 full mux function select. not used. can delete
<b>0x24</b>			<b>func_io3</b>	<b>register description</b>
[31:30]	RW	2'h0	reserved	
[29:24]	RW	6'h0	r_func_io15_sel	pad 15 full mux function select
[23:22]	RW	2'h0	reserved	
[21:16]	RW	6'h0	r_func_io14_sel	pad 14 full mux function select
[15:14]	RW	2'h0	reserved	
[13:8]	RW	6'h0	r_func_io13_sel	pad 13 full mux function select
[7:6]	RW	2'h0	reserved	
[5:0]	RW	6'h0	r_func_io12_sel	pad 12 full mux function select
<b>0x28</b>			<b>func_io4</b>	<b>register description</b>
[31:30]	RW	2'h0	reserved	
[29:24]	RW	6'h0	r_func_io19_sel	pad 19 full mux function select



[23:22]	RW	2'h0	reserved	
[21:16]	RW	6'h0	r_func_io18_sel	pad 18 full mux function select
[15:14]	RW	2'h0	reserved	
[13:8]	RW	6'h0	r_func_io17_sel	pad 17 full mux function select
[7:6]	RW	2'h0	reserved	
[5:0]	RW	6'h0	r_func_io16_sel	pad 16 full mux function select
<b>0x2c</b>			<b>func_io5</b>	<b>register description</b>
[31:30]	RW	2'h0	reserved	
[29:24]	RW	6'h0	r_func_io23_sel	pad 23 full mux function select
[23:22]	RW	2'h0	reserved	
[21:16]	RW	6'h0	r_func_io22_sel	pad 22 full mux function select
[15:14]	RW	2'h0	reserved	
[13:8]	RW	6'h0	r_func_io21_sel	pad 21 full mux function select
[7:6]	RW	2'h0	reserved	
[5:0]	RW	6'h0	r_func_io20_sel	pad 20 full mux function select
<b>0x30</b>			<b>func_io6</b>	<b>register description</b>
[31:30]	RW	2'h0	reserved	
[29:24]	RW	6'h0	r_func_io27sel	pad 27 full mux function select
[23:22]	RW	2'h0	reserved	
[21:16]	RW	6'h0	r_func_io26_sel	pad 26 full mux function select
[15:14]	RW	2'h0	reserved	
[13:8]	RW	6'h0	r_func_io25_sel	pad 25 full mux function select
[7:6]	RW	2'h0	reserved	
[5:0]	RW	6'h0	r_func_io24_sel	pad 24 full mux function select
<b>0x34</b>			<b>func_io7</b>	<b>register description</b>
[31:30]	RW	2'h0	reserved	
[29:24]	RW	6'h0	r_func_io31sel	pad 31 full mux function select
[23:22]	RW	2'h0	reserved	
[21:16]	RW	6'h0	r_func_io30_sel	pad 30 full mux function select
[15:14]	RW	2'h0	reserved	
[13:8]	RW	6'h0	r_func_io29_sel	pad 29 full mux function select
[7:6]	RW	2'h0	reserved	
[5:0]	RW	6'h0	r_func_io28_sel	pad 28 full mux function select
<b>0x38</b>			<b>func_io8</b>	<b>register description</b>
[31:22]	RW	10'h0	reserved	
[21:16]	RW	6'h0	r_func_io34_sel	pad 34 full mux function select
[15:14]	RW	2'h0	reserved	
[13:8]	RW	6'h0	r_func_io33_sel	pad 33 full mux function select
[7:6]	RW	2'h0	reserved	
[5:0]	RW	6'h0	r_func_io32_sel	pad 32 full mux function select
<b>0x4C</b>			<b>key_scan_in_en</b>	<b>register description</b>
[31:16]	RW	16'h0	reserved	
[15:0]	RW	16'h0	r_kscan_in_en	key scan in enable
<b>0x50</b>			<b>key_scan_out_en</b>	<b>register description</b>
[31:18]	RW	14'h0	reserved	
[17:0]	RW	18'h0	r_kscan_out_en	key scan out enable

**Table 10: Detailed IOMUX register**

## 3.9.2 Register table

Physical IO PAD control registers:

Base address: 4000\_F000

0xF008			IOCTL0
[31 : 30]	RW	2'd0	
[29 : 28]	RW	2'b0	pull up/down control of pin 09 00: floating, no pull up and pull down 01: weak pull up 10: strong pull up 11: pull down
[27]	RW	1'b0	wake up polarity select of pin 09 0: active POSEDGE 1: active NEGEDGE
[26 : 24]	RW	3'b110	P08 is used for test mode config pin
[23 : 22]	RW	2'b0	pull up/down control of pin 07 00: floating, no pull up and pull down 01: weak pull up 10: strong pull up 11: pull down
[21]	RW	1'b0	wake up polarity select of pin 07 0: active POSEDGE 1: active NEGEDGE
[20 : 19]	RW	2'b0	pull up/down control of pin 06 00: floating, no pull up and pull down 01: weak pull up 10: strong pull up 11: pull down
[18]	RW	1'b0	wake up polarity select of pin 06 0: active POSEDGE 1: active NEGEDGE
[17 : 16]	RW	2'b0	pull up/down control of pin 05 00: floating, no pull up and pull down 01: weak pull up 10: strong pull up 11: pull down
[15]	RW	1'b0	wake up polarity select of pin 05 0: active POSEDGE 1: active NEGEDGE
[14 : 13]	RW	2'b0	pull up/down control of pin 04

			00: floating, no pull up and pull down 01: weak pull up 10: strong pull up 11: pull down
[12]	RW	1'b0	wake up polarity select of pin 04 0: active POSEDGE 1: active NEGEDGE
[11 : 10]	RW	2'b11	pull up/down control of pin 03 00: floating, no pull up and pull down 01: weak pull up 10: strong pull up 11: pull down
[9]	RW	1'b0	wake up polarity select of pin 03 0: active POSEDGE 1: active NEGEDGE
[ 8 : 7]	RW	2'b0	pull up/down control of pin 02 00: floating, no pull up and pull down 01: weak pull up 10: strong pull up 11: pull down
[6]	RW	1'b0	wake up polarity select of pin 02 0: active POSEDGE 1: active NEGEDGE
[ 5 : 4]	RW	2'b0	pull up/down control of pin 01 00: floating, no pull up and pull down 01: weak pull up 10: strong pull up 11: pull down
[3]	RW	1'b0	wake up polarity select of pin 01 0: active POSEDGE 1: active NEGEDGE
[ 2 : 1]	RW	2'b0	pull up/down control of pin 00 00: floating, no pull up and pull down 01: weak pull up 10: strong pull up 11: pull down
[0]	RW	1'b0	wake up polarity select of pin 00 0: active POSEDGE 1: active NEGEDGE
<b>0xF00C</b>			<b>IOCTL1</b>
[31 : 30]	RW	2'd0	
[29 : 28]	RW	2'b0	pull up/down control of pin 19

			00: floating, no pull up and pull down 01: weak pull up 10: strong pull up 11: pull down
[27]	RW	1'b0	wake up polarity select of pin 19 0: active POSEDGE 1: active NEGEDGE
[26 : 25]	RW	2'b0	pull up/down control of pin 18 00: floating, no pull up and pull down 01: weak pull up 10: strong pull up 11: pull down
[24]	RW	1'b0	wake up polarity select of pin 18 0: active POSEDGE 1: active NEGEDGE
[23 : 22]	RW	2'b0	pull up/down control of pin 17 00: floating, no pull up and pull down 01: weak pull up 10: strong pull up 11: pull down
[21]	RW	1'b0	wake up polarity select of pin 17 0: active POSEDGE 1: active NEGEDGE
[20 : 19]	RW	2'b0	pull up/down control of pin 16 00: floating, no pull up and pull down 01: weak pull up 10: strong pull up 11: pull down
[18]	RW	1'b0	wake up polarity select of pin 16 0: active POSEDGE 1: active NEGEDGE
[17 : 16]	RW	2'b0	pull up/down control of pin 15 00: floating, no pull up and pull down 01: weak pull up 10: strong pull up 11: pull down
[15]	RW	1'b0	wake up polarity select of pin 15 0: active POSEDGE 1: active NEGEDGE
[14 : 13]	RW	2'b0	pull up/down control of pin 14 00: floating, no pull up and pull down 01: weak pull up

			10: strong pull up 11: pull down
[12]	RW	1'b0	wake up polarity select of pin 14 0: active POSEDGE 1: active NEGEDGE
[11 : 10]	RW	2'b0	pull up/down control of pin 13 00: floating, no pull up and pull down 01: weak pull up 10: strong pull up 11: pull down
[9]	RW	1'b0	wake up polarity select of pin 13 0: active POSEDGE 1: active NEGEDGE
[ 8 : 7]	RW	2'b0	pull up/down control of pin 12 00: floating, no pull up and pull down 01: weak pull up 10: strong pull up 11: pull down
[6]	RW	1'b0	wake up polarity select of pin 12 0: active POSEDGE 1: active NEGEDGE
[ 5 : 4]	RW	2'b0	pull up/down control of pin 11 00: floating, no pull up and pull down 01: weak pull up 10: strong pull up 11: pull down
[3]	RW	1'b0	wake up polarity select of pin 11 0: active POSEDGE 1: active NEGEDGE
[ 2 : 1]	RW	2'b0	pull up/down control of pin 10 00: floating, no pull up and pull down 01: weak pull up 10: strong pull up 11: pull down
[0]	RW	1'b0	wake up polarity select of pin 10 0: active POSEDGE 1: active NEGEDGE
<b>0xF010</b>			<b>IOCTL2</b>
[31 : 30]	RW	2'd0	
[29 : 28]	RW	2'b0	pull up/down control of pin 29 00: floating, no pull up and pull down 01: weak pull up

			10: strong pull up 11: pull down
[27]	RW	1'b0	wake up polarity select of pin 29 0: active POSEDGE 1: active NEGEDGE
[26 : 25]	RW	2'b0	pull up/down control of pin 28 00: floating, no pull up and pull down 01: weak pull up 10: strong pull up 11: pull down
[24]	RW	1'b0	wake up polarity select of pin 28 0: active POSEDGE 1: active NEGEDGE
[23 : 22]	RW	2'b0	pull up/down control of pin 27 00: floating, no pull up and pull down 01: weak pull up 10: strong pull up 11: pull down
[21]	RW	1'b0	wake up polarity select of pin 27 0: active POSEDGE 1: active NEGEDGE
[20 : 19]	RW	2'b0	pull up/down control of pin 26 00: floating, no pull up and pull down 01: weak pull up 10: strong pull up 11: pull down
[18]	RW	1'b0	wake up polarity select of pin 26 0: active POSEDGE 1: active NEGEDGE
[17 : 16]	RW	2'b11	pull up/down control of pin 25 00: floating, no pull up and pull down 01: weak pull up 10: strong pull up 11: pull down
[15]	RW	1'b0	wake up polarity select of pin 25 0: active POSEDGE 1: active NEGEDGE
[14 : 13]	RW	2'b11	pull up/down control of pin 24 00: floating, no pull up and pull down 01: weak pull up 10: strong pull up 11: pull down
[12]	RW	1'b0	wake up polarity select of pin 24

			0: active POSEDGE 1: active NEGEDGE
[11 : 10]	RW	2'b0	pull up/down control of pin 23 00: floating, no pull up and pull down 01: weak pull up 10: strong pull up 11: pull down
[9]	RW	1'b0	wake up polarity select of pin 23 0: active POSEDGE 1: active NEGEDGE
[ 8 : 7]	RW	2'b0	pull up/down control of pin 22 00: floating, no pull up and pull down 01: weak pull up 10: strong pull up 11: pull down
[6]	RW	1'b0	wake up polarity select of pin 22 0: active POSEDGE 1: active NEGEDGE
[ 5 : 4]	RW	2'b0	pull up/down control of pin 21 00: floating, no pull up and pull down 01: weak pull up 10: strong pull up 11: pull down
[3]	RW	1'b0	wake up polarity select of pin 21 0: active POSEDGE 1: active NEGEDGE
[ 2 : 1]	RW	2'b0	pull up/down control of pin 20 00: floating, no pull up and pull down 01: weak pull up 10: strong pull up 11: pull down
[0]	RW	1'b0	wake up polarity select of pin 20 0: active POSEDGE 1: active NEGEDGE

**Table 11: Physical IO PAD control registers**

### 3.10 GPIO

The General Purpose I/Os are a type of peripheral that can be mapped to physical I/O pads and programmed by software. The flexible GPIO are organized as two PORTs. Among them, PortA has bi-direction 18 bit lines, e.g., GPIO\_PORTA[17:0], while PortB has 17 bi-directional bit lines, e.g., PIO\_PORTB[16:0]. With default setting, physical pads: P00-P17 are connected to PortA; Pads P18-34 are connected to PortB, when all GPIOs are enabled, as described in the IOMUX table in IOMUX

section.

All PortA and PortB pins can be configured as bi-directional serial interface, by selecting as input or output direction, and their corresponding data can be either read from or written to registers. All PortA and PortB pins support wake-up, but only 18 PortA pins support interrupt. Also only PortA pins support debounce function.

Each GPIO pins can be pulled up to AVDD33 or pulled down to ground by adding pull up or pull down resistors to have default functions/states.

For more detailed info, please refer to “ST17Hxx GPIO Application Notes”, in software SDK document folder.

#	QFN48	QFN32	Default MODE	Default IN_OUT	IRQ	Wakeup	ANA_IO
0	GPIO_P00	√	jtag_dout	OUT	√	√	
1	GPIO_P01	√	jtag_din	IN	√	√	
2	GPIO_P02	√	jtag_tm	IN	√	√	
3	GPIO_P03	√	jtag_clk	IN	√	√	
4	GPIO_P04		GPIO	IN	√	√	
5	GPIO_P05		GPIO	IN	√	√	
6	GPIO_P06		GPIO	IN	√	√	
7	GPIO_P07		GPIO	IN	√	√	
8	TEST_MODE	√					
9	GPIO_P09	√	GPIO	IN	√	√	
10	GPIO_P10	√	GPIO	IN	√	√	
11	GPIO_P11		GPIO	IN	√	√	ADC_CH1N_P11
12	GPIO_P12		GPIO	IN	√	√	ADC_CH1P_P12
13	GPIO_P13		GPIO	IN	√	√	ADC_CH2N_P13
14	GPIO_P14	√	GPIO	IN	√	√	ADC_CH2P_P14
15	GPIO_P15	√	GPIO	IN	√	√	ADC_CH3N_P15
16	GPIO_P16	√	XTALI(ANA)	ANA	√	√	
17	GPIO_P17	√	XTALO(ANA)	ANA	√	√	
18	GPIO_P18	√	GPIO	IN		√	
19	GPIO_P19		GPIO	IN		√	
20	GPIO_P20	√	GPIO	IN		√	ADC_CH3P_P20
21	GPIO_P21		GPIO	IN		√	
22	GPIO_P22		GPIO	IN		√	
23	GPIO_P23	√	GPIO	IN		√	
24	GPIO_P24	√	GPIO	IN		√	
25	GPIO_P25	√	GPIO	IN		√	
26	GPIO_P26		GPIO	IN		√	
27	GPIO_P27		GPIO	IN		√	
28	GPIO_P28		GPIO	IN		√	
29	GPIO_P29		GPIO	IN		√	
30	GPIO_P30		GPIO	IN		√	
31	GPIO_P31	√	lenze_spi_t_ssn	IN		√	
32	GPIO_P32	√	lenze_spi_t_rx	IN		√	
33	GPIO_P33	√	lenze_spi_t_tx	OUT		√	
34	GPIO_P34	√	lenze_spi_t_sck	IN		√	



**Table 12: ST17Hxx GPIO Application Notes**

### 3.10.1 Register table

Below table are the Registers related to GPIOs.

Base address: 0x4000\_8000

OFFSET	TYPE	RESET	NAME	DESCRIPTION
<b>0x00</b>				
			<b>gpio_swporta_dr</b>	
[31:18]	RO	14'b0	Reserved	Reserved
[17:0]	RW	18'b0	Port A Data Register	Values written to this register are output on the I/O signals for Port A
<b>0x04</b>				
			<b>gpio_swporta_dds</b>	
[31:18]	RO	14'b0	Reserved	Reserved
[17:0]	RW	18'b0	Port A Data Direction Register	Values written to this register independently control the direction of the corresponding data bit in Port A 1'b0: Input 1'b1: Output
<b>0x08</b>				
			<b>gpio_swporta_ctl</b>	
[31:1]	RO	31'b0	Reserved	Reserved
[0]	RW	1'b0	Port A Data Source	The data and control source for a signal can come from either software or hardware 1'b0: Software mode 1'b1: Hardware mode
<b>0x0c</b>				
			<b>gpio_swportb_dr</b>	
[31:15]	RO	15'b0	Reserved	Reserved
[16:0]	RW	17'b0	Port B Data Register	Values written to this register are output on the I/O signals for Port B
<b>0x10</b>				
			<b>gpio_swportb_dds</b>	
[31:15]	RO	15'b0	Reserved	Reserved
[16:0]	RW	17'b0	Port B Data Direction Register	Values written to this register independently control the direction of the corresponding data bit in Port B 1'b0: Input 1'b1: Output
<b>0x14</b>				
			<b>gpio_swportb_ctl</b>	
[31:1]	RO	31'b0	Reserved	Reserved
[0]	RW	1'b0	Port B Data Source	The data and control source for a signal can come from either software or hardware 1'b0: Software mode 1'b1: Hardware mode
<b>0x30</b>				
			<b>gpio_inten</b>	
[31:18]	RO	14'b0	Reserved	Reserved
[17:0]	RW	18'b0	Interrupt enable	Allows each bit of Port A to be configured for interrupts 1'b0: Configure Port A bit as normal GPIO signal 1'b1: Configure Port A bit as interrupt
<b>0x34</b>				
			<b>gpio_intmask</b>	
[31:18]	RO	14'b0	Reserved	Reserved

[17:0]	RW	18'b0	Interrupt mask	Controls whether an interrupt on Port A can create an interrupt for the interrupt controller by not masking it 1'b0: Interrupt bits are unmasked 1'b1: Mask interrupt
<b>0x38</b>		<b>gpio_inttype_level</b>		
[31:18]	RO	14'b0	Reserved	Reserved
[17:0]	RW	18'b0	Interrupt level	Controls the type of interrupt that can occur on Port A 1'b0: Level-sensitive 1'b1: Edge-sensitive
<b>0x3c</b>		<b>gpio_int_polarity</b>		
[31:18]	RO	14'b0	Reserved	Reserved
[17:0]	RW	18'b0	Interrupt polarity	Controls the polarity of edge or level sensitivity that can occur on input of Port A 1'b0: Active-low or falling-edge 1'b1: Active-high or rising-edge
<b>0x40</b>		<b>gpio_intstatus</b>		
[31:18]	RO	14'b0	Reserved	Reserved
[17:0]	RO	18'b0	Interrupt status	Interrupt status of Port A
<b>0x44</b>		<b>gpio_raw_intstatus</b>		
[31:18]	RO	14'b0	Reserved	Reserved
[17:0]	RO	18'b0	Raw interrupt status	Raw interrupt of status of Port A
<b>0x48</b>		<b>gpio_debounce</b>		
[31:18]	RO	14'b0	Reserved	Reserved
[17:0]	RW	18'b0	Debounce enable	Controls whether an external signal that is the source of an interrupt needs to be debounced to remove any spurious glitches 1'b0: No debounce 1'b1: Enable debounce
<b>0x4c</b>		<b>gpio_porta_eoi</b>		
[31:18]	RO	14'b0	Reserved	Reserved
[17:0]	WO	18'b0	Clear interrupt	Controls the clearing of edge type interrupts from Port A 1'b0: No interrupt clear 1'b1: Clear interrupt
<b>0x50</b>		<b>gpio_ext_porta</b>		
[31:18]	RO	14'b0	Reserved	Reserved
[17:0]	RO	18'b0	External Port A	When Port A is configured as Input, then reading this location reads the values on the signal. When the data direction of Port A is set as Output, reading this location reads the data register for Port A
<b>x54</b>		<b>gpio_ext_portb</b>		
[31:17]	RO	15'b0	Reserved	Reserved
[16:0]	RO	17'b0	External Port B	When Port B is configured as Input, then reading this location reads the values on the signal. When the data direction of Port B is set as Output, reading this location reads the data register for Port B
<b>0x60</b>		<b>gpio_ls_sync</b>		

[31:1]	RO	31'b0	Reserved	Reserved
[0]	RW	1'b0	Synchronization level	Writing a 1 to this register results in all level-sensitive interrupts being synchronized to pclk_intr 1'b0: No synchronization to pclk_intr 1'b1: Synchronize to pclk_intr
<b>0x64</b>		<b>gpio_id_code</b>		
[31:16]	RO	16'b0	Reserved	Reserved
[15:0]	RO	16'b0	GPIO ID code	This is a user-specified code that a system can read. It can be used for chip identification, and so on
<b>0x6c</b>		<b>gpio_ver_id_code</b>		
[31:0]	RO	32'b0	GPIO Component Version	ASCII value for each number in the version
<b>0x74</b>		<b>gpio_config_reg1</b>		
[31:21]	RO	11'b0	Reserved	Reserved
[20:16]	RO	5'b0x0f	ENCODED_ID_WIDTH	The value of this register is equal to GPIO_ID_WIDTH-1
[15]	RO	1'b0	GPIO_ID	The value of this register is derived from the GPIO_ID configuration parameter 1'b0: Exclude 1'b1: Include
[14]	RO	1'b0	ADD_ENCODED_PARAMS	The value of this register is derived from the GPIO_ADD_ENCODED_PARAMS configuration parameter 1'b0: False 1'b1: True
[13]	RO	1'b0	DEBOUNCE	The value of this register is derived from the GPIO_DEBOUNCE configuration parameter 1'b0: Exclude 1'b1: Include
[12]	RO	1'b0	PORTA_INTR	The value of this register is derived from the GPIO_PORTA_INTR configuration parameter 1'b0: Exclude 1'b1: Include
[11]	RO	1'b0	Reserved	Reserved
[10]	RO	1'b0	Reserved	Reserved
[9]	RO	1'b0	HW_PORTB	The value of this register is derived from the GPIO_HW_PORTB configuration parameter 1'b0: Exclude 1'b1: Include
[8]	RO	1'b0	HW_PORTA	The value of this register is derived from the GPIO_HW_PORTA configuration parameter 1'b0: Exclude 1'b1: Include
[7]	RO	1'b0	Reserved	Reserved
[6]	RO	1'b0	Reserved	Reserved
[5]	RO	1'b0	PORTB_SINGLE_CTL	The value of this register is derived from the GPIO_PORTB_SINGLE_CTL configuration parameter 1'b0: False

				1'b1: True
[4]	RO	1'b0	PORTA_SINGLE_CTL	The value of this register is derived from the GPIO_PORTA_SINGLE_CTL configuration parameter 1'b0: False 1'b1: True
[3:2]	RO	2'b0x2	NUM_PORTS	The value of this register is derived from the GPIO_NUM_PORT configuration parameter 2'b00 1 2'b01 2 2'b10 3 2'b11 4
[1:0]	RO	2'b0x2	APB_DATA_WIDTH	The value of this register is derived from the GPIO_APB_DATA_WIDTH configuration parameter 2'b00 8 bits 2'b01 16 bits 2'b10 32 bits 2'b11 Reserved
<b>0x70</b>			<b>gpio_config_reg2</b>	
[31:10]	RO	22'b0	Reserved	Reserved
[9:5]	RO	5'b0x0f	ENCODED_ID_PWIDTH_B	The value of this register is equal to GPIO_PWIDTH_B-1
[4:0]	RO	5'b0x11	ENCODED_ID_PWIDTH_A	The value of this register is equal to GPIO_PWIDTH_A-1

**Table 13: GPIOs registers**

### 3.10.1 DC Characteristics

TA=25°C, VDD=3 V

PARAMETER	TEST CONDITIONS	Min.	TYP	Max.	Unit
Logic-0 input voltage				0.5	V
Logic-1 input voltage		2.4			V
Logic-0 input current	Input equals 0 V	-50		50	nA
Logic-1 input current	Input equals VDD	-50		50	nA
Logic-0 output voltage, 10-mA pins	Output load 10 mA			0.5	V
Logic-1 output voltage, 10-mA pins	Output load 10 mA	2.5			V

**Table 14: DC Characteristics**

## 4 Peripheral Blocks

### 4.1 2.4GHz Radio

The 2.4 GHz RF transceiver is designed to operate in the worldwide ISM frequency band at 2.4 to 2.4835 GHz. Radio modulation modes and configurable packet structure make the transceiver interoperable with *Bluetooth*® low energy (BLE) protocol implementations.

- General modulation format
  - FSK (configurable modulation index) with configurable Gaussian Filter Shaping
  - OQPSK with half-sine shaping
  - On-air data rates
  - 125kbps/250kbps/500kbps/1Mbps/2Mbps

- Transmitter with programmable output power of -20dBm to +10dBm, in 3dB steps
- RSSI function (1 dB resolution,  $\pm 2$  dB accuracy)
- Receiver sensitivity
  - -103dBm@125Kbps GFSK
  - -98dBm@500Kbps GFSK
  - -97dBm@1Mbps BLE
  - -94dBm@2Mbps BLE
- Embedded RF balun
- Integrated frac-N synthesizer with phase modulation

## 4.2 Timer/Counters (TIMER)

The implementation can include a 24-bit SysTick system timer, that extends the functionality of both the processor and the NVIC. When present, the NVIC part of the extension provides:

- A 24-bit system timer (SysTick)
- Additional configurable priority SysTick interrupt.
- See the ARMv7-M ARM for more information.

General purpose timers are included in the design. This timer is Synopsys DW\_apb\_timer. With the input clock running at 4Mhz.

### 4.2.1 Register table

The timer related registers are listed below, and there are two sets of identical timers.

Base address: Timer setA: 4000\_1000, timer\_setB: 4002\_1000

OFFSET	TYPE	RESET	NAME	DESCRIPTION
<b>0x00</b>			<b>Timer1LoadCount</b>	
[31:24]	RO	8'b0	Reserved	Reserved
[23:0]	RW	24'b0	Timer1 Load Count Register	Value to be loaded into Timer1
<b>0x04</b>			<b>Timer1CurrentValue</b>	
[31:24]	RO	8'b0	Reserved	Reserved
[23:0]	RO	24'b0	Timer1 Current Value Register	Current Value of Timer1
<b>0x08</b>			<b>Timer1ControlReg</b>	
[31:3]	RO	29'b0	Reserved	Reserved
[2]	RW	1'b0	Timer Interrupt Mask	Timer interrupt mask for Timer1 1'b0: not masked 1'b1: masked
[1]	RW	1'b0	Timer Mode	Timer mode for Timer1 1'b0: free-running mode 1'b1: user-defined count mode
[0]	RW	1'b0	Timer Enable	Timer enable bit for Timer1

1'b0: disable

1'b1: enable

<b>0x0c</b>			<b>Timer1EOI</b>	
[31:1]	RO	31'b0	Reserved	Reserved
[0]	RO	1'b0	Timer1 End of-Interrupt Register	Reading from this register returns all zeroes (0) and clears the interrupt from Timer1
<b>0x10</b>			<b>Timer1IntStatus</b>	
[31:1]	RO	31'b0	Reserved	Reserved
[0]	RO	1'b0	Timer1 Interrupt Status Register	Contains the interrupt status for Timer1
<b>0x14</b>			<b>Timer2LoadCount</b>	
[31:24]	RO	8'b0	Reserved	Reserved
[23:0]	RW	24'b0	Timer2 Load Count Register	Value to be loaded into Timer2
<b>0x18</b>			<b>Timer2CurrentValue</b>	
[31:24]	RO	8'b0	Reserved	Reserved
[23:0]	RO	24'b0	Timer2 Current Value Register	Current Value of TimerN
<b>0x1c</b>			<b>Timer2ControlReg</b>	
[31:3]	RO	29'b0	Reserved	Reserved
[2]	RW	1'b0	Timer Interrupt Mask	Timer interrupt mask for Timer2 1'b0: not masked 1'b1: masked
[1]	RW	1'b0	Timer Mode	Timer mode for Timer2 1'b0: free-running mode 1'b1: user-defined count mode
[0]	RW	1'b0	Timer Enable	Timer enable bit for Timer2 1'b0: disable 1'b1: enable
<b>0x20</b>			<b>Timer2EOI</b>	
[31:1]	RO	31'b0	Reserved	Reserved
[0]	RO	1'b0	Timer2 End of-Interrupt Register	Reading from this register returns all zeroes (0) and clears the interrupt from Timer2
<b>0x24</b>			<b>Timer2IntStatus</b>	
[31:1]	RO	31'b0	Reserved	Reserved
[0]	RO	1'b0	Timer2 Interrupt Status Register	Contains the interrupt status for Timer2
<b>0x28</b>			<b>Timer3LoadCount</b>	
[31:24]	RO	8'b0	Reserved	Reserved
[23:0]	RW	24'b0	Timer3 Load Count Register	Value to be loaded into Timer3
<b>0x2c</b>			<b>Timer3CurrentValue</b>	
[31:24]	RO	8'b0	Reserved	Reserved
[23:0]	RO	24'b0	Timer3 Current Value Register	Current Value of TimerN
<b>0x30</b>			<b>Timer3ControlReg</b>	
[31:3]	RO	29'b0	Reserved	Reserved

[2]	RW	1'b0	Timer Interrupt Mask	Timer interrupt mask for Timer3 1'b0: not masked 1'b1: masked
[1]	RW	1'b0	Timer Mode	Timer mode for Timer3 1'b0: free-running mode 1'b1: user-defined count mode
[0]	RW	1'b0	Timer Enable	Timer enable bit for Timer3 1'b0: disable 1'b1: enable
<b>0x34</b>		<b>Timer3EOI</b>		
[31:1]	RO	31'b0	Reserved	Reserved
[0]	RO	1'b0	Timer3 End of-Interrupt Register	Reading from this register returns all zeroes (0) and clears the interrupt from Timer3
<b>0x38</b>		<b>Timer3IntStatus</b>		
[31:1]	RO	31'b0	Reserved	Reserved
[0]	RO	1'b0	Timer3 Interrupt Status Register	Contains the interrupt status for Timer3
<b>0x3c</b>		<b>Timer4LoadCount</b>		
[31:24]	RO	8'b0	Reserved	Reserved
[23:0]	RW	24'b0	Timer4 Load Count Register	Value to be loaded into Timer4
<b>0x40</b>		<b>Timer4CurrentValue</b>		
[31:24]	RO	8'b0	Reserved	Reserved
[23:0]	RO	24'b0	Timer4 Current Value Register	Current Value of Timer4
<b>0x44</b>		<b>Timer4ControlReg</b>		
[31:3]	RO	29'b0	Reserved	Reserved
[2]	RW	1'b0	Timer Interrupt Mask	Timer interrupt mask for Timer4 1'b0: not masked 1'b1: masked
[1]	RW	1'b0	Timer Mode	Timer mode for Timer4 1'b0: free-running mode 1'b1: user-defined count mode
[0]	RW	1'b0	Timer Enable	Timer enable bit for Timer4 1'b0: disable 1'b1: enable
<b>0x48</b>		<b>Timer4EOI</b>		
[31:1]	RO	31'b0	Reserved	Reserved
[0]	RO	1'b0	Timer4 End of-Interrupt Register	Reading from this register returns all zeroes (0) and clears the interrupt from Timer4
<b>0x4c</b>		<b>Timer4IntStatus</b>		
[31:1]	RO	31'b0	Reserved	Reserved
[0]	RO	1'b0	Timer4 Interrupt Status Register	Contains the interrupt status for Timer4
<b>0xa0</b>		<b>TimersIntStatus</b>		
[31:4]	RO	28'b0	Reserved	Reserved
[3:0]	RO	4'b0	Timers Interrupt Status Register	Contains the interrupt status of all timers in the component

0: either timer\_intr or timer\_intr\_n is not active after masking  
 1: either timer\_intr or timer\_intr\_n is active after masking

0xa4			TimersEOI	
[31:4]	RO	28'b0	Reserved	Reserved
[3:0]	RO	4'b0	Timers End of-Interrupt Register	Reading this register returns all zeroes (0) and clears all active interrupts
0xa8			TimersRawIntStatus	
[31:4]	RO	28'b0	Reserved	Reserved
[3:0]	RO	4'b0	Timers Raw Interrupt Status Register	The register contains the unmasked interrupt status of all timers in the component 0: either timer_intr or timer_intr_n is not active prior to masking 1: either timer_intr or timer_intr_n is active prior to masking
0xac			TimersRawIntStatus	
[31:0]	RO	32'b0	Timers Component Version	Current revision number of the DW_apb_timers component

**Table 15: Timer registers**

## 4.3 Real Time Counter (RTC)

The Real Time Counter (RTC) module provides a generic, low power timer on the low-frequency clock source (LFCLK). The RTC features a 24 bit COUNTER, 12 bit (1/X) prescaler, capture/compare registers, and a tick event generator for low power, tickless RTOS implementation.

### 4.3.1 Register table

RTC related registers are listed below.

Base address: 4000\_F000

0xF024			RTCCTL	
[31 : 24]	RW	8'h0		
[23]	RW	1'b0		Counter overflow event enable. 1'b0: disable 1'b1: enable
[22]	RW	1'b0		Comparator 2 event enable. 1'b0: disable 1'b1: enable
[21]	RW	1'b0		Comparator 1 event enable. 1'b0: disable 1'b1: enable
[20]	RW	1'b0		Comparator 0 event enable. 1'b0: disable 1'b1: enable
[19]	RW	1'b0		RTC tick event enable.



			1'b0: disable 1'b1: enable
[18]	RW	1'b0	Counter overflow interrupt enable. 1'b0: disable 1'b1: enable
[17]	RW	1'b0	Comparator 2 interrupt enable. 1'b0: disable 1'b1: enable
[16]	RW	1'b0	Comparator 1 interrupt enable. 1'b0: disable 1'b1: enable
[15]	RW	1'b0	Comparator 0 interrupt enable. 1'b0: disable 1'b1: enable
[14]	RW	1'b0	RTC tick interrupt enable. 1'b0: disable 1'b1: enable
[13 : 2]	RW	12'h0	12bit prescaler for RTC counter frequency (32768/(PRESCALER+1)). Can be written only when RTC is stopped.
[1]	RW	1'b0	RTC counter clear bit. Write 1'b1 will clear RTC counter and after one clock this bit will return to 1'b0.
[0]	RW	1'b0	RTC run/stop control. 1'b0: stop 1'b1: run
<b>0xF028</b>			<b>RTCCNT</b>
[31 : 24]	RO	8'h0	
[23 : 0]	RO	24'h0	Writing 32'h5A5AA5A5 can trigger the overflow task that sets the RTC counter value to 24'hFFFFFF0 to allow SW test of the overflow condition. Reading can read the value of RTC counter (low 24 bits).
<b>0xF02C</b>			<b>RTCC0</b>
[31 : 24]	RW	8'h0	
[23 : 0]	RW	24'h0	Compare value of comparator 0
<b>0xF030</b>			<b>RTCC1</b>
[31 : 24]	RW	8'h0	
[23 : 0]	RW	24'h0	Compare value of comparator 1
<b>0xF034</b>			<b>RTCC2</b>
[31 : 24]	RW	8'h0	
[23 : 0]	RW	24'h0	Compare value of comparator 2
<b>0xF038</b>			<b>RTCFLAG</b>
[31 : 4]	R	28'h0	
[3]	RO	1'b0	Overflow result flag.

[2]	RO	1'b0	Compare result flag of comparator 2.
[1]	RO	1'b0	Compare result flag of comparator 1.
[0]	RO	1'b0	Compare result flag of comparator 0.

**Table 16: RTC registers**

## 4.4 AES-ECB Encryption (ECB)

The ECB encryption block supports 128 bit AES encryption. It can be used for a range of cryptographic functions like hash generation, digital signatures, and keystream generation for data encryption/decryption.

### 4.4.1 Register table

AES-ECB related registers are listed below.

Base address:4004\_0000

OFFSET	TYPE	RESET	NAME	DESCRIPTION
<b>0x00</b>				<b>AES layer enable register</b>
[31:1]	—	31'b0	reserved	
[0]	RW	1'b0	Enable	Setting this bit to “1” will enable AES to do TX/RX
<b>0x04</b>				<b>AES layer control register</b>
[31:17]	—	15'b0	reserved	
[16]	RW	1'b0	Fifo out/in (PDU)	if pdu is little-endian set 0;if pdu is big-endian set 1
[15:12]	—	4'b0	reserved	
				[11]:data out: if it is little-endian set 0 if it is big-endian set 1
[11:8]	RW	4'b0	Enginne revert	[10]:xor data :1 [9]: key : if it is little-endian set 0 if it is big-endian set 1
				[8]:data if it is little-endian set 0 if it is big-endian set 1
[7:5]	—	3'b0	reserved	
[4]	RW	1'b0	Aes_single mode	Aes single mode
[3]	RW	1'b0	Code_mode	Encrypt /decrypt
[2:0]	—	3'b0	reserved	
<b>0x08</b>				<b>AES reserved register</b>
[31:0]	—	32'b0	reserved	
<b>0x0c</b>				<b>AES plen &amp; aad register</b>
[31:16]	—	16'b0	reserved	
[15:8]	RW	8'b0	plen	Packet length
[7:0]	RW	8'b0	aad	aad
<b>0x10</b>				<b>AES interrupt mask register</b>
[31:4]	—	28'b0	reserved	

[3:0]	RW	4'b0	Aes interrupt enable	[0]: encrypt done;[1]: decrypt failed;[2]: decrypt ok;[3] single mode done
<b>0x14</b>				<b>AES interrupt status register</b>
[31:4]	—	28'b0	reserved	
[3:0]	RO	4'b0	Aes interrupt status	[0]: encrypt done;[1]: decrypt failed;[2]: decrypt ok;[3] single mode done
<b>0x18</b>				<b>AES reserved register</b>
[31:0]	—	32'b0	reserved	
<b>0x1C</b>				<b>AES reserved register</b>
[31:0]	—	32'b0	reserved	
<b>0x20</b>				<b>AES key0 register</b>
[31:0]	RW	32'b0	Key0[31:0]	Key[31:0]
<b>0x24</b>				<b>AES key1 register</b>
[31:0]	RW	32'b0	Key1[31:0]	Key[63:32]
<b>0x28</b>				<b>AES key2 register</b>
[31:0]	RW	32'b0	Key2[31:0]	Key[95:64]
<b>0x2C</b>				<b>AES key3 register</b>
[31:0]	RW	32'b0	Key3[31:0]	Key[127:96]
<b>0x30</b>				<b>AES nonce0 register</b>
[31:0]	RW	32'b0	Nonce0[31:0]	Single mode:data_in[31:0];ECB-CCM:Nonce[31:0]
<b>0x34</b>				<b>AES nonce1 register</b>
[31:0]	RW	32'b0	Nonce1[31:0]	Single mode:data_in[31:0];ECB-CCM:Nonce[63:32]
<b>0x38</b>				<b>AES nonce2 register</b>
[31:0]	RW	32'b0	Nonce2[31:0]	Single mode:data_in[31:0];ECB-CCM:Nonce[95:64]
<b>0x3C</b>				<b>AES nonce3 register</b>
[31:0]	RW	32'b0	Nonce3[31:0]	Single mode:data_in[31:0];ECB-CCM:Nonce[127:96]
<b>0x50</b>				<b>AES data out 0(single mode) register</b>
[31:0]	RO	32'b0	Data_o0[31:0]	Data_out[31:0]
<b>0x54</b>				<b>AES data out 1(single mode) register</b>
[31:0]	RO	32'b0	Data_o1[31:0]	Data_out[63:32]
<b>0x58</b>				<b>AES data out 2(single mode) register</b>
[31:0]	RO	32'b0	Data_o2[31:0]	Data_out[95:64]
<b>0x5C</b>				<b>AES data out 3(single mode) register</b>
[31:0]	RO	32'b0	Data_o3[31:0]	Data_out[127:96]
<b>0x100</b>				<b>AES memory (0x0100~0x01FC)</b>
[31:0]	RW	32'b0	memory write	Writing offset address 0x100~0x1FC will write data into aes memory

**Table 17: AES-ECB registers**

## 4.5 Random Number Generator (RNG)

The Random Number Generator (RNG) generates true non-deterministic random numbers based on internal thermal noise. These random numbers are suitable for cryptographic purposes. The RNG does not require a seed value.

## 4.6 Watchdog Timer (WDT)

A count down watchdog timer using the low-frequency clock source (LFCLK) offers configurable and robust protection against application lock-up. The watchdog can be paused during long CPU sleep periods for low power applications and when the debugger has halted the CPU.

## 4.7 SPI (SPI)

The SPI interface supports 3 serial synchronous protocols which are SPI, SSP and Microwire serial protocols. SPI wrapper contains one SPI master and one SPI slave. They are logically exclusive. Only one block is alive at a time. The operation mode for master mode and slave mode is controlled by PERI\_MASTER\_SELECT Register in COM block.

bit	Reset value	Definition
1	0	SPI1 is master mode when set
0	0	SPI0 is master mode when set

**Table 18: PERI\_MASTER\_SELECT Register bit definition  
(base address = 0x4000\_302C)**

## 4.8 I2C (I2c0, I2c1 Two Independent Instances)

This I2C block support 100Khz, and 400Khz modes. It also supports 7-bit address and 10-bit address. It has built-in configurable spike suppression function for both lines.

## 4.9 I2S

I2S wrapper contains one I2S master and one I2S slave. They are logically exclusive. Only one block is alive at a time. The operation mode for master mode and slave mode is controlled by PERI\_MASTER\_SELECT Register in COM block.

bit	Reset value	Definition
3	0	I2S1 is master mode when set
2	0	I2S0 is master mode when set

**Table 19: PERI\_MASTER\_SELECT Register bit definition  
(base address = 0x4002\_302C)**

## 4.10 UART (UART)

The Universal Asynchronous Receiver/Transmitter offers fast, full-duplex, asynchronous serial communication with built-in flow control (CTS, RTS) support in HW up to 1Mbps baud. Parity checking and generation for the 9th data bit are supported.

The GPIOs used for each UART interface line can be chosen from any GPIO on the device and are independently configurable. This enables great flexibility in device pin out and enables efficient use of board space and signal routing.

## 4.11 DMIC/AMIC Data Path

The voice in interface supports one analog MIC (SAR-ADC) and two digital MIC (L+R), different output sample rate (64KHz, 32KHz, 16KHz and 8KHz), and different voice compress algorithm. For the Digital MIC, PDM signal is sampled at 1.28MHz(4x320KHz). L channel is sampled at raising edge, R channel is sampled at falling edge. For PCM-LOG and CVDS, output data rate is 64Kbps (8KHz x 8bit).

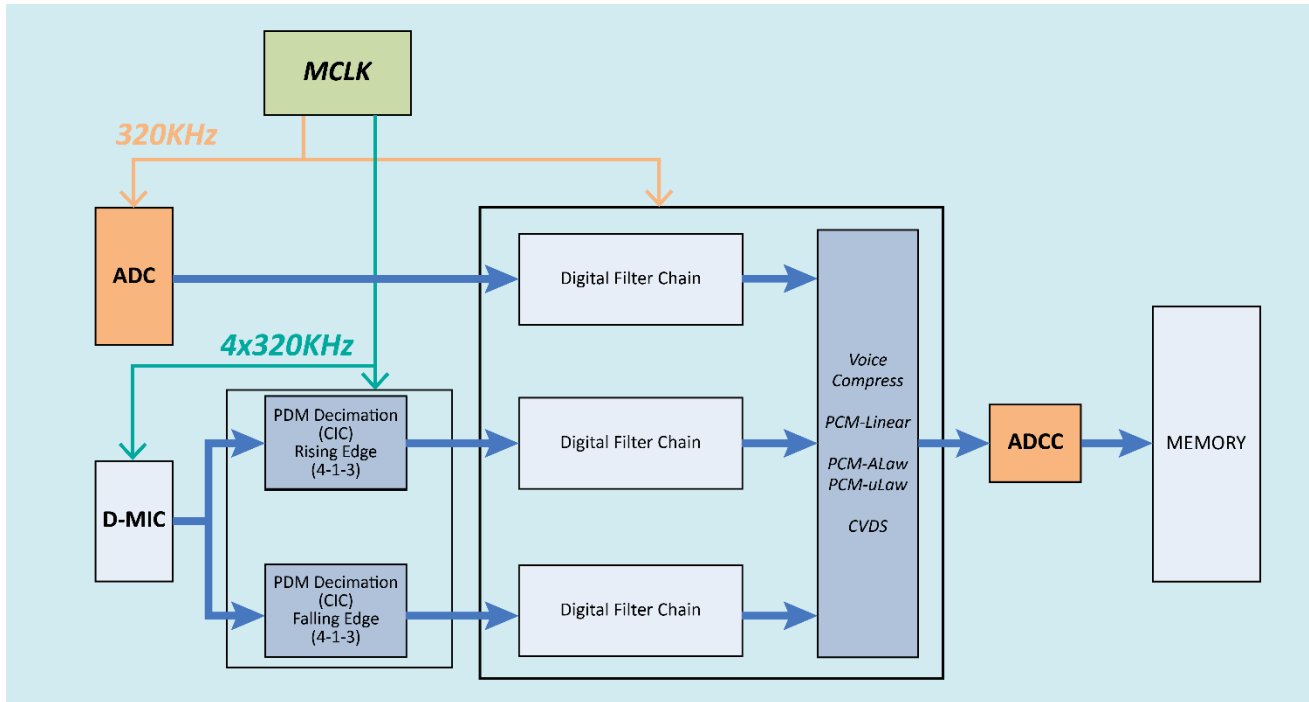

Figure 11: Block Diagram of Voice In Interface

### 4.11.1 Filter Chain Design

For D-MIC input, PDM Decimation (CIC) will convert the 1-bit PDM signal to 12 bit PCM signal. And the sample rate will be converted from 1.28MHz to 320KHz. The output data of the PDM Decimation will be connected to the Digital Filter chain.

For the A-MIC input, SAR-ADC will convert the signal to 12bit 320KHz digital samples. The Digital Filter chain will process the data same as the D-MIC path.

The Output sample rate of the Digital filter chain is programmable. 64KHz, 32KHz, 16KHz, 8KHz. The maximum value of the sample's bit-width is 16bit.

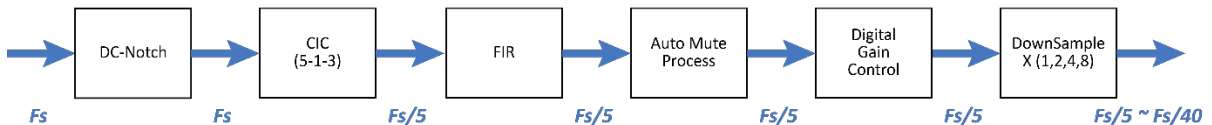

Figure 12: Digital Filter Chain

### 4.11.2 Auto Mute Process

Signal Level Estimate will check the input signal level with configurable window size. Mute threshold can be updated according to the signal level estimation or being configured by the register. There are two thresholds, one for MUTE\_ON, another for MUTE\_OFF. Gain step of MUTE\_ON and MUTE\_OFF can be configured individually.

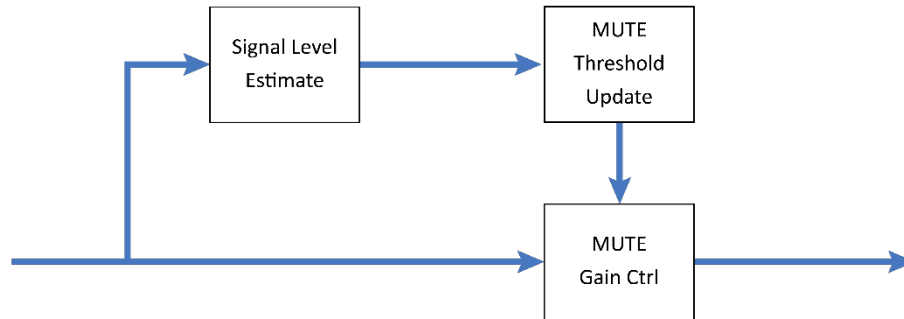

Figure 13: Auto Mute Process

### 4.11.3 Digital Gain Control

Digital gain is implemented by one Look up table. The gain error has been controlled within 0.05dB.

### 4.11.4 Voice Compression

PCM-LOG support u-Law and a-Law. According to the ITU-G711 standard. The input data is 13~14bit @ 8KHz. The output data is 8bit @ 8KHz, 64Kbps. Also, it support 64Kbps CVSD according to the BT standard. Its Input is 16bit @64KHz, and its output is 1bit @ 64KHz. PCM-Linear is for the raw data without compression.

## 4.12 Pulse Width Modulation (PWM)

ST17Hxx supports 6 channels of Pulse Width Modulation (PWM) outputs. PWM outputs generate waveforms with variable duty cycle or pulse width programmed by registers. And each of the 6 PWM outputs can be individually programmed. Their duty cycles are controlled by programming individual counters associated with each channel.

The master clock is 16MHz. For each PWM outputs, first there is a prescaler (pre-divider) with division ratio of 2 to 128 (only 2<sup>N</sup> division ratios are supported), followed by another 16bit counter with programmable max count, denoted as top\_count. When the 16bit counter counts from 0 to top\_count, it resets back to 0. So the frequency of the PWM is given by:

$$\text{Freq\_PWM} = 16\text{MHz} / (\text{N\_prescaler} * \text{N\_top\_count});$$

A threshold counter number can be programmed, when the 16bit counter reaches the threshold, PWM output toggles. So the duty cycle is:

$$\text{Duty\_cycle\_PWM} = \text{N\_threshold}/\text{N\_top\_count};$$

The polarity of the PWM can also be programmed, which indicates output 1 or 0 when counter is below/above the threshold. A PWM waveform vs counter values are illustrated in the following Figure 13, where the polarity is positive. Also in this case the counter ramps up and then resets, we call it “up mode”.

There is also a “up and down mode”, where the counter ramps up to count\_top and then ramps down, instead of reset.

As discussed above, the key register bits for one PWM channel are: 16bit top\_count, 16bit threshold count, 3bit prescaler count, PWM polarity, PWM mode (up or up/down), PWM enable, and PWM load enable (load new settings). All 6 PWM channels can be individually programmed by registers with addresses from

0x4000\_E004 to 0x4000\_E044. In addition, one should enable registers 0x4000\_E000<0><4> to allow all PWM channels can be programmed. For details please refer to documents of PHY62xx register tables.

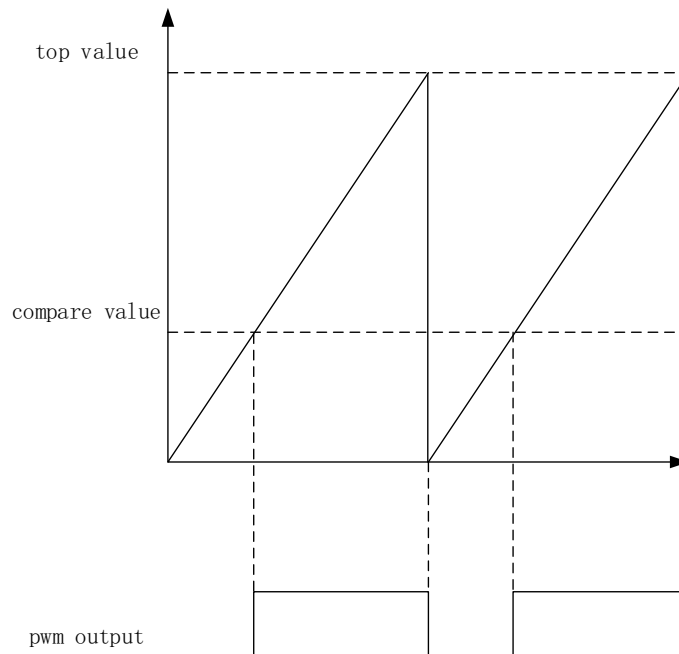

Figure 14: PWM operation

## 4.12.1 Register table

PWM related registers are listed below.

Base address: 4000\_E000

OFFSET	TYPE	RESET	NAME	DESCRIPTION
0x00			PWMEN	pwm enable
[31 : 18]	RO	14'b0	reserved	Reserved
[17]	RW	1'b0	pwm_load_45	load parameter of PWM channel 4, 5. need to be conjunction with setting bit16 of PWMxCTL0 registers. 1'b0: no load 1'b1: load
[16]	RW	1'b0	pwm_en_45	enable of PWM channel 4, 5. need to be conjunction with setting bit0 of PWMxCTL0 registers. 1'b0: disable 1'b1: enable
[15]	RW	1'b0	pwm_load_23	load parameter of PWM channel 2, 3. need to be conjunction with setting bit16 of PWMxCTL0 registers. 1'b0: no load 1'b1: load
[14]	RW	1'b0	pwm_en_23	enable of PWM channel 2, 3. need to be conjunction with setting bit0 of PWMxCTL0 registers. 1'b0: disable 1'b1: enable
[13]	RW	1'b0	pwm_load_01	load parameter of PWM channel 0, 1. need to be conjunction with setting bit16 of PWMxCTL0 registers.

				1'b0: no load 1'b1: load
[12]	RW	1'b0	pwm_en_01	enable of PWM channel 0, 1. need to be conjunction with setting bit0 of PWMxCTL0 registers. 1'b0: disable 1'b1: enable
[11]	RW	1'b0	pwm_load_345	load parameter of PWM channel 3, 4, 5. need to be conjunction with setting bit16 of PWMxCTL0 registers. 1'b0: no load 1'b1: load
[10]	RW	1'b0	pwm_en_345	enable of PWM channel 3, 4, 5. need to be conjunction with setting bit0 of PWMxCTL0 registers. 1'b0: disable 1'b1: enable
[9]	RW	1'b0	pwm_load_012	load parameter of PWM channel 0, 1, 2. need to be conjunction with setting bit16 of PWMxCTL0 registers. 1'b0: no load 1'b1: load
[8]	RW	1'b0	pwm_en_012	enable of PWM channel 0, 1, 2. need to be conjunction with setting bit0 of PWMxCTL0 registers. 1'b0: disable 1'b1: enable
[7 : 5]	RO	3'b0	reserved	Reserved
[4]	RW	1'b0	pwm_load_all	load parameter of all six PWM channels. need to be conjunction with setting bit16 of PWMxCTL0 registers. 1'b0: no load 1'b1: load
[3 : 1]	RO	3'b0	reserved	Reserved
[0]	RW	1'b0	pwm_en_all	enable of all six PWM channels. need to be conjunction with setting bit0 of PWMxCTL0 registers. 1'b0: disable 1'b1: enable
<b>0x04</b>			<b>PWM0CTL0</b>	<b>pwm channel 0 contrl reigister</b>
[31]	RW	1'b0	pwm0_load_instant	instant load parameter of PWM channel 0. 1'b0: no load 1'b1: instant load
[30 : 17]	RO	14'b0	reserved	Reserved
[16]	RW	1'b0	pwm0_load	load parameter of PWM channel 0. 1'b0: no load 1'b1: load
[15]	RO	1'b0	reserved	Reserved
[14 : 12]	RW	3'b0	pwm0_clk_div	clock prescaler of PWM channel 0. 3'b000: pwm_clk is divided by 1 for count clock 3'b001: pwm_clk is divided by 2 for count clock 3'b010: pwm_clk is divided by 4 for count clock 3'b011: pwm_clk is divided by 8 for count clock



				3'b100: pwm_clk is divided by 16 for count clock 3'b101: pwm_clk is divided by 32 for count clock 3'b110: pwm_clk is divided by 64 for count clock 3'b111: pwm_clk is divided by 128 for count clock
[11 : 9]	RO	3'b0	reserved	Reserved
[8]	RW	1'b0	pwm0_cnt_mode	count mode of PWM channel 0. 1'b0: up mode 1'b1: up and down mode
[7 : 5]	RO	3'b0	reserved	Reserved
[4]	RW	1'b0	pwm0_polarity	output polarity setting of PWM channel 0. 1'b0: rising edge. Second edge within the PWM period is rising 1'b1: falling edge. Second edge within the PWM period is falling
[3 : 1]	RO	3'b0	reserved	Reserved
[0]	RW	1'b0	pwm0_en	enable of PWM channel 0. 1'b0: disable 1'b1: enable
<b>0x08</b>			<b>PWM0CTL1</b>	<b>pwm channel 0 conter value setting</b>
[31 : 16]	RW	16'b0	pwm0_cmp_val	the compare value of PWM channel 0
[15 : 0]	RW	16'b0	pwm0_cnt_top	the counter top value of PWM channel 0
<b>0x10</b>			<b>PWM1CTL0</b>	<b>pwm channel 1 contrl reigister</b>
[31]	RW	1'b0	pwm1_load_instant	instant load parameter of PWM channel 1. 1'b0: no load 1'b1: instant load
[30 : 17]	RO	14'b0	reserved	Reserved
[16]	RW	1'b0	pwm1_load	load parameter of PWM channel 1. 1'b0: no load 1'b1: load
[15]	RO	1'b0	reserved	Reserved
[14 : 12]	RW	3'b0	pwm1_clk_div	clock prescaler of PWM channel 1. 3'b000: pwm_clk is divided by 1 for count clock 3'b001: pwm_clk is divided by 2 for count clock 3'b010: pwm_clk is divided by 4 for count clock 3'b011: pwm_clk is divided by 8 for count clock 3'b100: pwm_clk is divided by 16 for count clock 3'b101: pwm_clk is divided by 32 for count clock 3'b110: pwm_clk is divided by 64 for count clock 3'b111: pwm_clk is divided by 128 for count clock
[11 : 9]	RO	3'b0	reserved	Reserved
[8]	RW	1'b0	pwm1_cnt_mode	count mode of PWM channel 1. 1'b0: up mode 1'b1: up and down mode
[7 : 5]	RO	3'b0	reserved	Reserved
[4]	RW	1'b0	pwm1_polarity	output polarity setting of PWM channel 1.

				1'b0: rising edge. Second edge within the PWM period is rising 1'b1: falling edge. Second edge within the PWM period is falling
[ 3 : 1]	RO	3'b0	reserved	Reserved
[0]	RW	1'b0	pwm1_en	enable of PWM channel 1. 1'b0: disable 1'b1: enable
<b>0x14</b>			<b>PWM1CTL1</b>	<b>pwm channel 1 conter value setting</b>
[31 : 16]	RW	16'b0	pwm1_cmp_val	the compare value of PWM channel 1
[15 : 0]	RW	16'b0	pwm1_cnt_top	the counter top value of PWM channel 1
<b>0x1C</b>			<b>PWM2CTLO</b>	<b>pwm channel 2 contrl reigister</b>
[31]	RW	1'b0	pwm2_load_instant	instant load parameter of PWM channel 2. 1'b0: no load 1'b1: instant load
[30 : 17]	RO	14'b0	reserved	Reserved
[16]	RW	1'b0	pwm2_load	load parameter of PWM channel 2. 1'b0: no load 1'b1: load
[15]	RO	1'b0	reserved	Reserved
[14 : 12]	RW	3'b0	pwm2_clk_div	clock prescaler of PWM channel 2. 3'b000: pwm_clk is divided by 1 for count clock 3'b001: pwm_clk is divided by 2 for count clock 3'b010: pwm_clk is divided by 4 for count clock 3'b011: pwm_clk is divided by 8 for count clock 3'b100: pwm_clk is divided by 16 for count clock 3'b101: pwm_clk is divided by 32 for count clock 3'b110: pwm_clk is divided by 64 for count clock 3'b111: pwm_clk is divided by 128 for count clock
[11 : 9]	RO	3'b0	reserved	Reserved
[8]	RW	1'b0	pwm2_cnt_mode	count mode of PWM channel 2. 1'b0: up mode 1'b1: up and down mode
[ 7 : 5]	RO	3'b0	reserved	Reserved
[4]	RW	1'b0	pwm2_polarity	output polarity setting of PWM channel 2. 1'b0: rising edge. Second edge within the PWM period is rising 1'b1: falling edge. Second edge within the PWM period is falling
[ 3 : 1]	RO	3'b0	reserved	Reserved
[0]	RW	1'b0	pwm2_en	enable of PWM channel 2. 1'b0: disable 1'b1: enable
<b>0x20</b>			<b>PWM2CTL1</b>	<b>pwm channel 2 conter value setting</b>
[31 : 16]	RW	16'b0	pwm2_cmp_val	the compare value of PWM channel 2
[15 : 0]	RW	16'b0	pwm2_cnt_top	the counter top value of PWM channel 2

0x28			PWM3CTL0	pwm channel 3 contrl reigister
[31]	RW	1'b0	pwm3_load_instant	instant load parameter of PWM channel 3. 1'b0: no load 1'b1: instant load
[30 : 17]	RO	14'b0	reserved	Reserved
[16]	RW	1'b0	pwm3_load	load parameter of PWM channel 3. 1'b0: no load 1'b1: load
[15]	RO	1'b0	reserved	Reserved
[14 : 12]	RW	3'b0	pwm3_clk_div	clock prescaler of PWM channel 3. 3'b000: pwm_clk is divided by 1 for count clock 3'b001: pwm_clk is divided by 2 for count clock 3'b010: pwm_clk is divided by 4 for count clock 3'b011: pwm_clk is divided by 8 for count clock 3'b100: pwm_clk is divided by 16 for count clock 3'b101: pwm_clk is divided by 32 for count clock 3'b110: pwm_clk is divided by 64 for count clock 3'b111: pwm_clk is divided by 128 for count clock
[11 : 9]	RO	3'b0	reserved	Reserved
[8]	RW	1'b0	pwm3_cnt_mode	count mode of PWM channel 3. 1'b0: up mode 1'b1: up and down mode
[7 : 5]	RO	3'b0	reserved	Reserved
[4]	RW	1'b0	pwm3_polarity	output polarity setting of PWM channel 3. 1'b0: rising edge. Second edge within the PWM period is rising 1'b1: falling edge. Second edge within the PWM period is falling
[3 : 1]	RO	3'b0	reserved	Reserved
[0]	RW	1'b0	pwm3_en	enable of PWM channel 3. 1'b0: disable 1'b1: enable
0x2C			PWM3CTL1	pwm channel 0 conter value setting
[31 : 16]	RW	16'b0	pwm3_cmp_val	the compare value of PWM channel 3
[15 : 0]	RW	16'b0	pwm3_cnt_top	the counter top value of PWM channel 3
0x34			PWM4CTL0	pwm channel 4 contrl reigister
[31]	RW	1'b0	pwm4_load_instant	instant load parameter of PWM channel 4. 1'b0: no load 1'b1: instant load
[30 : 17]	RO	14'b0	reserved	Reserved
[16]	RW	1'b0	pwm4_load	load parameter of PWM channel 4. 1'b0: no load 1'b1: load
[15]	RO	1'b0	reserved	Reserved
[14 : 12]	RW	3'b0	pwm4_clk_div	clock prescaler of PWM channel 4. 3'b000: pwm_clk is divided by 1 for count clock 3'b001: pwm_clk is divided by 2 for count clock

				3'b010: pwm_clk is divided by 4 for count clock 3'b011: pwm_clk is divided by 8 for count clock 3'b100: pwm_clk is divided by 16 for count clock 3'b101: pwm_clk is divided by 32 for count clock 3'b110: pwm_clk is divided by 64 for count clock 3'b111: pwm_clk is divided by 128 for count clock
[11 : 9]	RO	3'b0	reserved	Reserved
[8]	RW	1'b0	pwm4_cnt_mode	count mode of PWM channel 4. 1'b0: up mode 1'b1: up and down mode
[7 : 5]	RO	3'b0	reserved	Reserved
[4]	RW	1'b0	pwm4_polarity	output polarity setting of PWM channel 4. 1'b0: rising edge. Second edge within the PWM period is rising 1'b1: falling edge. Second edge within the PWM period is falling
[3 : 1]	RO	3'b0	reserved	Reserved
[0]	RW	1'b0	pwm4_en	enable of PWM channel 4. 1'b0: disable 1'b1: enable
<b>0x38</b>			<b>PWM4CTL1</b>	<b>pwm channel 4 conter value setting</b>
[31 : 16]	RW	16'b0	pwm4_cmp_val	the compare value of PWM channel 4
[15 : 0]	RW	16'b0	pwm4_cnt_top	the counter top value of PWM channel 4
<b>0x40</b>			<b>PWM5CTL0</b>	<b>pwm channel 5 contrl reigister</b>
[31]	RW	1'b0	pwm5_load_instant	instant load parameter of PWM channel 5. 1'b0: no load 1'b1: instant load
[30 : 17]	RO	14'b0	reserved	Reserved
[16]	RW	1'b0	pwm5_load	load parameter of PWM channel 5. 1'b0: no load 1'b1: load
[15]	RO	1'b0	reserved	Reserved
[14 : 12]	RW	3'b0	pwm5_clk_div	clock prescaler of PWM channel 5. 3'b000: pwm_clk is divided by 1 for count clock 3'b001: pwm_clk is divided by 2 for count clock 3'b010: pwm_clk is divided by 4 for count clock 3'b011: pwm_clk is divided by 8 for count clock 3'b100: pwm_clk is divided by 16 for count clock 3'b101: pwm_clk is divided by 32 for count clock 3'b110: pwm_clk is divided by 64 for count clock 3'b111: pwm_clk is divided by 128 for count clock
[11 : 9]	RO	3'b0	reserved	Reserved
[8]	RW	1'b0	pwm5_cnt_mode	count mode of PWM channel 5. 1'b0: up mode 1'b1: up and down mode
[7 : 5]	RO	3'b0	reserved	Reserved
[4]	RW	1'b0	pwm5_polarity	output polarity setting of PWM channel 5.

				1'b0: rising edge. Second edge within the PWM period is rising 1'b1: falling edge. Second edge within the PWM period is falling
[ 3 : 1]	RO	3'b0	reserved	Reserved
[0]	RW	1'b0	pwm5_en	enable of PWM channel 5. 1'b0: disable 1'b1: enable
<b>0x44</b>			<b>PWM5CTL1</b>	<b>pwm channel 5 conter value setting</b>
[31 : 16]	RW	16'b0	pwm5_cmp_val	the compare value of PWM channel 5
[15 : 0]	RW	16'b0	pwm5_cnt_top	the counter top value of PWM channel 5

**Table 20: PWM registers**

## 4.13 Quadrature Decoder (QDEC)

The quadrature decoder provides buffered decoding of quadrature-encoded sensor signals with input debounce filters. It is suitable for mechanical and optical sensors. The sample period and accumulation are configurable to match application requirements. The quadrature decoder has three-axis capability and index channel support. It can be programmed as 4x/2x/1x count mode.

### 4.13.1 Register table

Quadrature decoder related registers are listed below.

Base address: 4000\_B000

OFFSET	TYPE	RESET	NAME	DESCRIPTION
<b>0x00</b>				
[31:9]	—	23'b0	reserved	
[8]	RW	1'b0	chnz_en	enable channel z
[7:5]	—	3'b0	reserved	
[4]	RW	1'b0	chny_en	enable channel y
[3:1]	—	3'b0	reserved	
[0]	RW	1'b0	chnx_en	enable channel x
<b>0x04</b>			<b>int_enable</b>	
[31:30]	—	2'b0	reserved	
[29]	RW	1'b0	int_quaz_02f_en	enable interupt, counter addition overflow ( from 0 to F)
[28]	RW	1'b0	int_quaz_f20_en	enable interupt, counter subtraction overflow ( from F to 0)
[27]	RW	1'b0	int_quay_02f_en	
[26]	RW	1'b0	int_quay_f20_en	
[25]	RW	1'b0	int_quax_02f_en	
[24]	RW	1'b0	int_quax_f20_en	
[23]	—	1'b0	reserved	
[22]	RW	1'b0	incz_int_mode	index counter interupt mode 0 index changes, 1 index equals hit
[21]	—	1'b0	reserved	
[20]	RW	1'b0	int_incz_en	enable index counter interupt

[19]	—	1'b0	reserved	
[18]	RW	1'b0	quaz_int_mode	quadrature counter interrupt mode 0 index changes, 1 index equals hit
[17]	—	1'b0	reserved	
[16]	RW	1'b0	int_quaz_en	enable quadrature counter interrupt
[15]	—	1'b0	reserved	
[14]	RW	1'b0	incy_int_mode	
[13]	—	1'b0	reserved	
[12]	RW	1'b0	int_incy_en	
[11]	—	1'b0	reserved	
[10]	RW	1'b0	quay_int_mode	
[9]	—	1'b0	reserved	
[8]	RW	1'b0	int_quay_en	
[7]	—	1'b0	reserved	
[6]	RW	1'b0	incx_int_mode	
[5]	—	1'b0	reserved	
[4]	RW	1'b0	int_incx_mode	
[3]	—	1'b0	reserved	
[2]	RW	1'b0	quax_int_mode	
[1]	—	1'b0	reserved	
[0]	RW	1'b0	int_quax_en	
<b>0x08</b>			<b>int_clear</b>	
[31:30]	—	2'b0	reserved	
[29]	WC	1'b0	quaz_02f_clr	clear 0 to F interrupt
[28]	WC	1'b0	quaz_f20_clr	clear F to 0 interrupt
[27]	WC	1'b0	quay_02f_clr	
[26]	WC	1'b0	quay_f20_clr	
[25]	WC	1'b0	quax_02f_clr	
[24]	WC	1'b0	quax_f20_clr	
[23:21]	—	3'b0	reserved	
[20]	WC	1'b0	incz_clr	clear index counter interrupt
[19:17]	—	3'b0	reserved	
[16]	WC	1'b0	quaz_clr	clear quadrature counter interrupt
[15:13]	—	3'b0	reserved	
[12]	WC	1'b0	incy_clr	
[11:9]	—	3'b0	reserved	
[8]	WC	1'b0	quay_clr	
[7:5]	—	3'b0	reserved	
[4]	WC	1'b0	incx_clr	
[3:1]	—	3'b0	reserved	
[0]	WC	1'b0	quax_clr	
<b>0x0C</b>			<b>int_status</b>	
[31:30]	—	2'b0	reserved	
[29]	RO	1'b0	int_quaz_02f	0 to F interrupt status
[28]	RO	1'b0	int_quaz_f20	F to 0 interrupt status
[27]	RO	1'b0	int_quay_02f	
[26]	RO	1'b0	int_quay_f20	
[25]	RO	1'b0	int_quax_02f	
[24]	RO	1'b0	int_quax_f20	

[23:21]	—	3'b0	reserved	
[20]	RO	1'b0	int_inc_z	index counter interrupt status
[19:17]	—	3'b0	reserved	
[16]	RO	1'b0	int_qua_z	quadrature counter interrupt status
[15:13]	—	3'b0	reserved	
[12]	RO	1'b0	int_inc_y	
[11:9]	—	3'b0	reserved	
[8]	RO	1'b0	int_qua_y	
[7:5]	—	3'b0	reserved	
[4]	RO	1'b0	int_inc_x	
[3:1]	—	3'b0	reserved	
[0]	RO	1'b0	int_qua_x	
<b>0x10</b>				
[31:18]	—	14'b0	reserved	
[17:16]	RW	2'b0	incx_mode	index counter mode 00 high level 01 positive edge 10 negative edge 11 pos and neg edge
[15:2]	—	14'b0	reserved	
[1:0]	RW	2'b0	quax_mode	quadrature counter mode 01 mode 1x , 10 mode 2x, 11 mode 3x
<b>0x14</b>				
[31:0]	RW	32'b0	quax_hit	to compare with qua_cnt, trigger interrupt
<b>0x18</b>				
[31:0]	RW	32'b0	incx_hit	to compare with inc_cnt, trigger interrupt
<b>0x1C</b>				
[31:0]	RO	32'b0	quax_cnt	quadrature counter
<b>0x20</b>				
[31:0]	RO	32'b0	incx_cnt	index counter
<b>0x24</b>				
[31:18]	—	14'b0	reserved	
[17:16]	RW	2'b0	incy_mode	
[15:2]	—	14'b0	reserved	
[1:0]	RW	2'b0	quay_mode	
<b>0x28</b>				
[31:0]	RW	32'b0	quay_hit	
<b>0x2C</b>				
[31:0]	RW	32'b0	incy_hit	
<b>0x30</b>				
[31:0]	RO	32'b0	quay_cnt	
<b>0x34</b>				
[31:0]	RO	32'b0	incy_cnt	
<b>0x38</b>				
[31:18]	—	14'b0	reserved	
[17:16]	RW	2'b0	incz_mode	
[15:2]	—	14'b0	reserved	
[1:0]	RW	2'b0	quaz_mode	
<b>0x3C</b>				
[31:0]	RW	32'b0	quaz_hit	

<b>0x40</b>				
[31:0]	RW	32'b0	incz_hit	
<b>0x44</b>				
[31:0]	RO	32'b0	quaz_cnt	
<b>0x48</b>				
[31:0]	RO	32'b0	incz_cnt	
<b>0x3FC</b>				
[31:0]	RW	32'b0	dummy	
[15]	RO	1'b0	reserved	Reserved

**Table 21: Quadrature decoder registers**

## 4.14 Key Scan (KSCAN)

Keyscan supports key matrix with upto 16 rows by 18 columns. Each individual rows or columns can be enabled or disabled through register settings. GPIO pins can be configured to be used for key scan. A few key scan Parameters can be set through registers, including polarity (low or high indicating key pressed); support multi-key-press or only single-key-press; de-bounce time (the time duration a key press is deemed valid) from 0 to 128mS with 255us step.

A valid key press can trigger an interrupt when keyscan interrupt is enabled. After a keyscan interrupt is serviced, writing 1 to the interrupt state register bit can clear the state bit.

The keyscan has a manual mode and an auto mode. For manual mode, when a keyscan interrupt is received, it is up to the MCU/software to scan the keyscan output pins and check the input pins, to determine which keys have been pressed. Manual mode is relatively slow and need CPU to process. On the contrary, in automode keyscan will automatically scan the output/input pins, and store the row/column info corresponding to the key pressed into read only registers, then trigger an interrupt for software to retrieve key press information.

### 4.14.1 Register table

Key scan related registers are listed below.

Base address: 4002\_4000

OFFSET	TYPE	RESET	NAME	DESCRIPTION
<b>0xC0</b>				
[31:24]	RW	8'h00	mkdi	key scan debounce interval, 0-255, unit: 512uS
[23]	RW	1'b0	mk_pol	key matrix polarity, 0: active scan high, active sense high; 1: active scan low, active sense low;
[22]	RO	1'b0	reserved	no use/as
[21]	RW	1'b0	asact	auto scan on activity: 0, no auto scan, 1, auto scan on activity
[20]	RW	1'b0	imkp	ignore multi key press
[19:2]	RW	18'h0	ms	matrix scan outputs enable: 1: enable, 0: disable
[1]	RW	1'b0	ks_ie	key scan interrupt enable
[0]	RW	1'b0	ks_en	key scan enable
<b>0xC4</b>				
[31:18]	RO	14'b0	reserved	
[17]	WC	1'b0	mkp	key pressed indicator, 0: no key press, 1: key pressed, write 1 to clear



[16:1]	RO	16'h0FFF	mr	key scan inputs states
[0]	WC	1'b0	mi	interrupt state, write 1 to clear interrupt, 0: no interrupt, 1: interrupt issued,
<b>0xC8</b>				
[31:13]	RO	19'b0	reserved	
[12]	RO	1'b0	so	scan on: 1: auto scan is on going, 0: scan off
[11:10]	RO	2'b0	mukp	multi key pressed, 00, no key press, 01: 1 key press, 10, more than 1 key pressed
[9:5]	RO	5'h1F	rp	row of key pressed, only for 1 key pressed case
[4:0]	RO	5'h1F	cp	column of key pressed, only for 1 key pressed case
<b>0xCC</b>				
[31:16]	RO	16'h0	mkc1	column 1 key pressed, for multi key pressed case
[15:0]	RO	16'h0	mkc0	column 0 key pressed, for multi key pressed case
<b>0xD0</b>				
[31:16]	RO	16'h0	mkc3	column 3 key pressed, for multi key pressed case
[15:0]	RO	16'h0	mkc2	column 2 key pressed, for multi key pressed case
<b>0xD4</b>				
[31:16]	RO	16'h0	mkc5	column 5 key pressed, for multi key pressed case
[15:0]	RO	16'h0	mkc4	column 4 key pressed, for multi key pressed case
<b>0xD8</b>				
[31:16]	RO	16'h0	mkc7	column 7 key pressed, for multi key pressed case
[15:0]	RO	16'h0	mkc6	column 6 key pressed, for multi key pressed case
<b>0xDC</b>				
[31:16]	RO	16'h0	mkc9	column 9 key pressed, for multi key pressed case
[15:0]	RO	16'h0	mkc8	column 8 key pressed, for multi key pressed case
<b>0xE0</b>				
[31:16]	RO	16'h0	mkc11	column 11 key pressed, for multi key pressed case
[15:0]	RO	16'h0	mkc10	column 10 key pressed, for multi key pressed case
<b>0xE4</b>				
[31:16]	RO	16'h0	mkc13	column 13 key pressed, for multi key pressed case
[15:0]	RO	16'h0	mkc12	column 12 key pressed, for multi key pressed case
<b>0xE8</b>				
[31:16]	RO	16'h0	mkc15	column 15 key pressed, for multi key pressed case
[15:0]	RO	16'h0	mkc14	column 14 key pressed, for multi key pressed case
<b>0xEC</b>				
[31:16]	RO	16'h0	mkc17	column 17 key pressed, for multi key pressed case
[15:0]	RO	16'h0	mkc16	column 16 key pressed, for multi key pressed case
<b>0xF0</b>				
[31:16]	RW	16'h0	reserved	
[15:0]	RW	16'h0FFF	mk_in_en	enable/disable key scan inputs: 0: disable, 1: enable
<b>0xF4</b>				
[31:2]	RW	30'h0	reserved	
[1:0]	RW	2'b0	ks_pena_i	
<b>0xF8</b>				
[31:0]	RW	32'h0	ks_iosel	

**Table 22: Key scan related registers**

## 4.15 Analog to Digital Converter (ADC) with Programmable Gain Amplifier (PGA)

The 12bit SAR ADC has total 10 inputs. Among them, there are two for PGA inputs, and two differential inputs for the on-chip temperature sensor. The other six inputs can be programmed to 3 pair differential inputs or six single-ended inputs. There is a manual mode with which the ADC can be configured to convert a specific input in single-ended or differential and with a specific ADC clock rate. There is also an auto sweep mode, namely all enabled input channels can be swept automatically in order by the ADC and the converted data will be stored at corresponding memory locations.

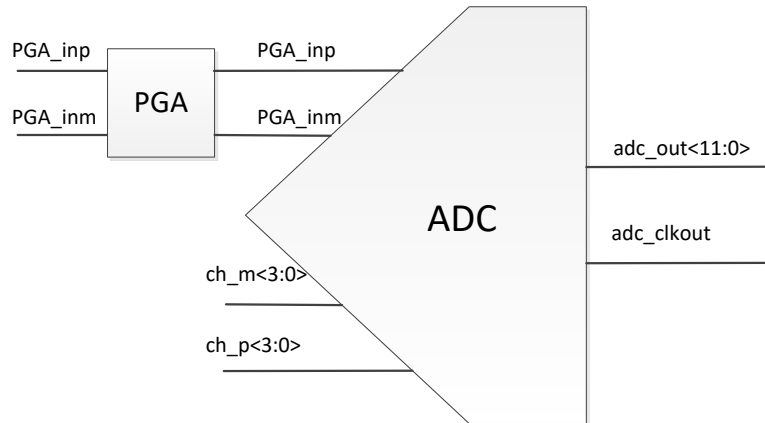

Figure 15: ADC

### 4.15.1 PGA Path

The PGA provides 42dB gain range from 0dB to 42dB in 3dB steps.

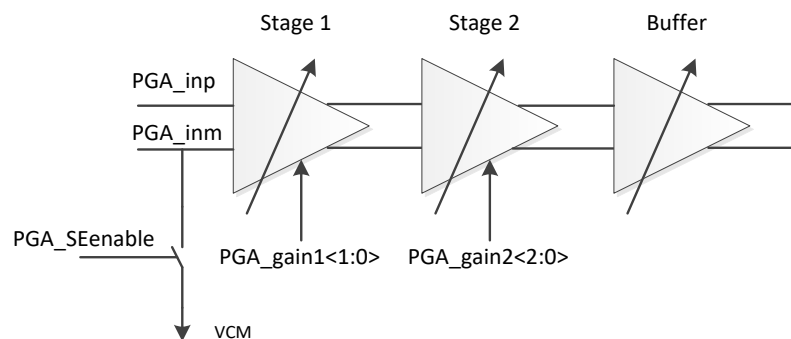

Figure 16: PGA path

pga_gain1<1>	pga_gain1<0>	Stage1 gain (dB)	pga_gain2<2>	pga_gain2<1>	pga_gain2<0>	Stage2 gain(dB)
0	0	0	0	0	0	0
0	1	12	0	0	1	3
1	0	24	0	1	0	6
			0	1	1	9

	1	0	0	12
	1	0	1	15
	1	1	0	18

**Table 23: PGA gain**

Set PGA\_SEenable to “1”, PGA will be set to Single-ended mode by pulling the PGA into its Common-mode voltage.

### 4.15.2 ADC Path

By default the ADC is configured in manual mode. In this mode, the ADC clock rate can be configured to 80k/160k/320k sample per second. Select the pair of inputs and configure it to differential or singled-ended (positive or negative). By default it is differential. After enabling, the ADC will take samples with the configured clock rate and store the data to a channel dependent memory location. For each channel a memory size of 128Byte is allocated, when it is full an interrupt bit will be flagged. Each sample of 12bits takes 2 Byte memory space.

0x4000_F07C		Register Description
[4]	adc_ctrl_override	Set manual mode: 1: manual, 0: auto. Default 1
[3]	adc_tconv_sel	For auto mode only, adc conversion time sel: 0: 1.56us, 1: 2.34us
[2:1]	adc_clk_sel	For manual mode only, clkssel: 00: 80k, 01: 160k, 10: 320k
[0]	max_rate_256k_320k	For auto mode only, max rate base: 0, 256k, 1, 320k
0x4000_F048		Register Description
[11]	adc12b_semode_enm	For manual mode only: 12 bit ADC single-ended mode negative side enable. Bit<11> Bit<8> cannot both be 1; 1: Enable single-ended mode 0: Differential mode
[8]	Adc12b_semode_epm	For manual mode only: 12 bit ADC single-ended mode positive side enable. Bit<8> Bit<11> cannot both be 1; 1: Enable single-ended mode 0: Differentail mode
[7:5]	Channel configure	For manual mode only: 12 bit ADC input channel select control bits. adc12_ctrl<3:1> Selected channel 000 PGA inputs, differential 001 Temperature sensing inputs, differential 010 input A, positive and negative 011 input B, positive and negative 100 input C, positive and negative
[3]	ADC enable	12b ADC power up control. 1: Power up ADC 0: Power down ADC
Memory start/end addresses		ADC channels
4005_0400 – 4005_047F		PAG inputs, differential
4005_0480 – 4005_04FF		Temperature sensing, differential
4005_0500 – 4005_057F		Input A, positive or differential

4005_0580 – 4005_05FF	Input A, negative	
4005_0600 – 4005_067F	Input B, positive or differential	
4005_0680 – 4005_06FF	Input B, negative	
4005_0700 – 4005_077F	Input C, positive or differential	
4005_0780 – 4005_07FF	Input C, negative	
<b>0x4005_003C</b>	<b>ADC interrupt status</b>	<b>Register Description</b>
[7]		input C, negative
[6]		Input C, positive or differential
[5]		Input B, negative
[4]		Input B, positive or differential
[3]		Input A, negative
[2]		Input A, positive or differential
[1]		Temperature sensing, differential
[0]		PGA inputs, differential
<b>0x4005_0038</b>	<b>ADC interrupt write clear</b>	<b>Register Description</b>
[7]		input C, negative, write 1 to clear
[6]		Input C, positive or differential, write 1 to clear
[5]		Input B, negative, write 1 to clear
[4]		Input B, positive or differential, write 1 to clear
[3]		Input A, negative, write 1 to clear
[2]		Input A, positive or differential, write 1 to clear
[1]		Temperature sensing, differential, write 1 to clear
[0]		PGA inputs, differential, write 1 to clear

**Table 24: ADC manual mode**

ADC can also be configured into auto channel sweep mode by setting the “adc\_ctrl\_override” bit to 0, with which the enabled channels will be sampled in the configured order automatically. The ten ADC input channels can be configured by programming their corresponding registers. Their configurations include sampling time, enable/disable, differential/single-ended, and continuous sampling/single-shot, based on the following register table. The sampled data is stored in the corresponding memory locations as in manual mode.

<b>0x4000_F06C</b>	<b>ADC_CTL0</b>	<b>Register Description</b>
[31:16]	Temperature sensing, auto mode, differential	channel config: [3:0] sample time, for max rate 320k: 2T to 62T, step 4T; for max rate 256k, 3T to 63T, step 4T, T is period of 1.28MHz; [4] channel enable; [5] differential 1 or single-ended 0; [6] continuous 0 or one shot 1. For auto channel sweep mode only
[15:0]	PGA inputs, differential	channel config: [3:0] sample time, for max rate 320k: 2T to 62T, step 4T; for max rate 256k, 3T to 63T, step 4T, T is period of 1.28MHz; [4] channel enable; [5] differential 1 or single-ended 0; [6] continuous 0 or one shot 1. For auto channel sweep mode only
<b>0x4000_F070</b>	<b>ADC_CTL1</b>	<b>Register Description</b>

[31:16]	Inputs A, negative	channel config: [3:0] sample time, for max rate 320k: 2T to 62T, step 4T; for max rate 256k, 3T to 63T, step 4T, T is period of 1.28MHz; [4] channel enable; [5] differential 1 or single-ended 0; [6] continuous 0 or one shot 1. For auto channel sweep mode only
[15:0]	Input A, positive or differential	channel config: [3:0] sample time, for max rate 320k: 2T to 62T, step 4T; for max rate 256k, 3T to 63T, step 4T, T is period of 1.28MHz; [4] channel enable; [5] differential 1 or single-ended 0; [6] continuous 0 or one shot 1. For auto channel sweep mode only
<b>0x4000_F074</b>	<b>ADC_CTL2</b>	<b>Register Description</b>
[31:16]	Input B, negative	channel config: [3:0] sample time, for max rate 320k: 2T to 62T, step 4T; for max rate 256k, 3T to 63T, step 4T, T is period of 1.28MHz; [4] channel enable; [5] differential 1 or single-ended 0; [6] continuous 0 or one shot 1. For auto channel sweep mode only
[15:0]	Input B, positive or differential	channel config: [3:0] sample time, for max rate 320k: 2T to 62T, step 4T; for max rate 256k, 3T to 63T, step 4T, T is period of 1.28MHz; [4] channel enable; [5] differential 1 or single-ended 0; [6] continuous 0 or one shot 1. For auto channel sweep mode only
<b>0x4000_F078</b>	<b>ADC_CTL3</b>	<b>Register Description</b>
[31:16]	Input C, negative	channel config: [3:0] sample time, for max rate 320k: 2T to 62T, step 4T; for max rate 256k, 3T to 63T, step 4T, T is period of 1.28MHz; [4] channel enable; [5] differential 1 or single-ended 0; [6] continuous 0 or one shot 1. For auto channel sweep mode only
[15:0]	Input C, positive or differential	channel config: [3:0] sample time, for max rate 320k: 2T to 62T, step 4T; for max rate 256k, 3T to 63T, step 4T, T is period of 1.28MHz; [4] channel enable; [5] differential 1 or single-ended 0; [6] continuous 0 or one shot 1. For auto channel sweep mode only

**Table 25: ADC channel configurations**

### 4.15.3 ADC Channel <3:0> Connectivity

PGA inputs	hardwired
temp sensing	hardwired
aio<0>	Input A negative
aio<1>	Input A positive

aio<2>	Input B negative
aio<3>	Input B positive
aio<4>	Input C negative
aio<9>	Input C positive

**Table 26: ADC channel connectivity**

Aio<9, 4:0> and PGA inputs(Aio<7:8>) can be selected through an analog Mux by programming aio\_pass<7:0> or aio\_attn<7:0>. For example, register 0x4000\_F020<8><0> set to 01, then Aio<0> is connected to ADC input A positive node.

0x4000_F020		Register Description
[13:8]	Attenuation ctrl	attn[5:0]. analogIO control for {aio<9>, aio<4>, aio<3>, aio<2>, aio<1>, aio<0>}. {attn[x], pass[x]}: 00 switch off 01 pass 10 attenuate to 1/4 11 NC
[5:0]	pass ctrl	pass[5:0]. analogIO control for {aio<9>, aio<4>, aio<3>, aio<2>, aio<1>, aio<0>}. {attn[x], pass[x]}: 00 switch off 01 pass 10 attenuate to 1/4 11 NC note: analog IO sharing gpio<11>/aio<0> gpio<12>/aio<1> gpio<13>/aio<2> gpio<14>/aio<3> gpio<15>/aio<4> gpio<16>/aio<5>/32K XTAL input gpio<17>/aio<6>/32K XTAL output gpio<18>/aio<7>/pga in+ gpio<19>/aio<8>/pga in- gpio<20>/aio<9>/mic bias

**Table 27: analog Mux**

## 5 Absolute Maximum Ratings

Maximum ratings are the extreme limits to which ST17H63 can be exposed without permanently damaging it. Exposure to absolute maximum ratings for prolonged periods of time may affect the reliability of the ST17H63. **Table 32** specifies the absolute maximum ratings for ST17H63.

Symbol	Parameter	Min.	Max.	Unit
<b>Supply voltages</b>				
VDD3		-0.3	+3.6	V
DEC			1.32	V
VSS			0	V
<b>I/O pin voltage</b>				
VIO		-0.3	VDD + 0.3	V
<b>Environmental</b>				
	Storage temperature	-40	+125	°C
MSL	Moisture Sensitivity Level		2	
ESD HBM	Human Body Model Class 2		2	kV
ESD CDMQF	Charged Device Model (QFN48, 7x7 mm package)		500	V
<b>Flash memory</b>				
	Endurance		100 000	write/erase cycles
	Retention		10 years at 40 °C	
	Number of times an address can be written between erase cycles		2	times

**Table 28: Absolute maximum ratings**



## 6 Operating Conditions

The operating conditions are the physical Parameters that ST17H63 can operate within as defined in **Table 33**.

Symbol	Parameter	Min.	Typ.	Max.	Units
VDD3	Supply voltage, normal mode	1.8	3	3.6	V
tr_VDD	Supply rise time (0 V to 1.8 V)			100	ms
TA	Operating temperature	-40	27	125	°C

**Table 29: Operating conditions**



## 7 Radio Transceiver

### 7.1 Radio Current Consumption

Parameter	Description	MIN	TYP	MAX	UNIT
Tx only at 0dBm	with internal DC-DC @3V		8		mA
Rx Only	with internal DC-DC @3V		8		mA

**Table 30: Radio current consumption**

### 7.2 Transmitter Specification

Parameter	Description	MIN	TYP	MAX	UNIT
RF Max Output Power			10		dBm
RF Min Output Power			-20		dBm
OBW for BLE 1Mbps	20dB occupy-bandwidth for BLE modulation 1Mbps		1100		KHz
OBW for BLE 2Mbps	20dB occupy-bandwidth for BLE modulation 2Mbps		2300		KHz
OBW for GFSK 500Kbps	20dB occupy-bandwidth for GFSK modulation 2Mbps		1100		KHz
OBW for GFSK 125bps	20dB occupy-bandwidth for GFSK modulation 2Mbps		1100		KHz
Error Vector Measure	Offset EVM for OQPSK modulation		0.02		
FDEV for BLE 1Mbps	Frequency deviation for GFSK modulation 1Mbps	160		250	KHz
FDEV for BLE 2Mbps	Frequency deviation for GFSK modulation 2Mbps	320		500	KHz

**Table 31: Transmitter specification**

### 7.3 Receiver Specification

#### 7.3.1 RX BLE 1Mbps GFSK

Parameter	Description	MIN	TYP	MAX	UNIT
Rx Sensitivity	Sensitivity test 1Mbps BLE ideal transmitter, 37 Byte BER=1E-3		-97		dBm
co-channel rejection	modulated interferer in channel, 37 Byte BER=1E-3		-6		I/C dB
Selectivity +/-1MHz	Wanted signal at -67dBm, modulated interferer at +/- 1MHz, 37 Byte BER=1E-3		7		I/C dB
Selectivity +/-2MHz	Wanted signal at -67dBm, modulated interferer at +/- 2MHz, 37 Byte BER=1E-3		45		I/C dB

Selectivity +-3MHz	Wanted signal at -67dBm, modulated interferer at +/- 3MHz, 37 Byte BER=1E-3	50	I/C dB
Selectivity +-4MHz	Wanted signal at -67dBm, modulated interferer at +/- 4MHz, 37 Byte BER=1E-3	50	I/C dB
Selectivity +-5MHz or More	Wanted signal at -67dBm, modulated interferer at >= +/- 5MHz, 37 Byte BER=1E-3	55	I/C dB
Selectivity Imag frequency	Wanted signal at -67dBm, modulated interferer at imagefrequency, 37 Byte BER=1E-3	22	I/C dB
Intermodulation	Wanted signal at 2402MHz, -64dBm, Two interferers at 2405 and 2408 MHz respectively, at the given power level, 37 Byte BER=1E-3	-20	dBm
Carrier Frequency Offset Tolerance		+/- 350	KHz
Sample Clock Offset Tolerance		+/- 120	ppm

**Table 32: RX BLE 1Mbps GFSK**

### 7.3.2 RX BLE 2Mbps GFSK

Parameter	Description	MIN	TYP	MAX	UNIT
Rx Sensitivity	Sensitivity test 2Mbps BLE ideal transmitter, 37 Byte BER=1E-3		-94		dBm
co-channel rejection	modulated interferer in channel, 37 Byte BER=1E-3		-6		I/C dB
Selectivity +-1MHz	Wanted signal at -67dBm, modulated interferer at +/- 1MHz, 37 Byte BER=1E-3		-5		I/C dB
Selectivity +-2MHz	Wanted signal at -67dBm, modulated interferer at +/- 2MHz, 37 Byte BER=1E-3		9		I/C dB
Selectivity +-3MHz	Wanted signal at -67dBm, modulated interferer at +/- 3MHz, 37 Byte BER=1E-3		30		I/C dB
Selectivity +-4MHz	Wanted signal at -67dBm, modulated interferer at +/- 4MHz, 37 Byte BER=1E-3		40		I/C dB
Selectivity +-5MHz or More	Wanted signal at -67dBm, modulated interferer at >= +/- 5MHz, 37 Byte BER=1E-3		55		I/C dB
Selectivity Imag frequency	Wanted signal at -67dBm, modulated interferer at imagefrequency, 37 Byte BER=1E-3		22		I/C dB
Intermodulation	Wanted signal at 2402MHz, -64dBm, Two interferers at 2405 and 2408 MHz respectively, at the given power level, 37 Byte BER=1E-3		-20		dBm
Carrier Frequency Offset Tolerance			+/- 350		KHz
Sample Clock Offset Tolerance			+/- 120		ppm

**Table 33: RX BLE 2Mbps GFSK**

### 7.3.3 RX 500Kbps GFSK

Parameter	Description	MIN	TYP	MAX	UNIT
Rx Sensitivity	Sensitivity test 500Kbps BLE ideal transmitter, 37 Byte BER=1E-3		-98		dBm
co-channel rejection	modulated interferer in channel, 37 Byte BER=1E-3		-4		I/C dB
Selectivity +/- 1MHz	Wanted signal at -67dBm, modulated interferer at +/- 1MHz, 37 Byte BER=1E-3		10		I/C dB
Selectivity +/- 2MHz	Wanted signal at -67dBm, modulated interferer at +/- 2MHz, 37 Byte BER=1E-3		45		I/C dB
Selectivity +/- 3MHz	Wanted signal at -67dBm, modulated interferer at +/- 3MHz, 37 Byte BER=1E-3		50		I/C dB
Selectivity +/- 4MHz	Wanted signal at -67dBm, modulated interferer at +/- 4MHz, 37 Byte BER=1E-3		50		I/C dB
Selectivity +/- 5MHz or More	Wanted signal at -67dBm, modulated interferer at >= +/- 5MHz, 37 Byte BER=1E-3		55		I/C dB
Selectivity Imag frequency	Wanted signal at -67dBm, modulated interferer at imagefrequency, 37 Byte BER=1E-3		24		I/C dB
Intermodulation	Wanted signal at 2402MHz, -64dBm, Two interferers at 2405 and 2408 MHz respectively, at the given power level, 37 Byte Ber=1E-3		-19		dBm
Carrier Frequency Offset Tolerance			+350		KHz
Sample Clock Offset Tolerance			+120		ppm

Table 34: RX 500Kbps GFSK

### 7.3.4 RX 125Kbps GFSK

Parameter	Description	MIN	TYP	MAX	UNIT
Rx Sensitivity	Sensitivity test 125Kbps BLE ideal transmitter, 37 Byte BER=1E-3		-103		dBm
co-channel rejection	modulated interferer in channel, 37 Byte BER=1E-3		-1		I/C dB
Selectivity +/- 1MHz	Wanted signal at -67dBm, modulated interferer at +/- 1MHz, 37 Byte BER=1E-3		-11		I/C dB
Selectivity +/- 2MHz	Wanted signal at -67dBm, modulated interferer at +/- 2MHz, 37 Byte BER=1E-3		45		I/C dB
Selectivity +/- 3MHz	Wanted signal at -67dBm, modulated interferer at +/- 3MHz, 37 Byte BER=1E-3		50		I/C dB
Selectivity +/- 4MHz	Wanted signal at -67dBm, modulated interferer at +/- 4MHz, 37 Byte BER=1E-3		50		I/C dB

Selectivity +/- 5MHz or More	Wanted signal at -67dBm, modulated interferer at >= +/- 5MHz, 37 Byte BER=1E-3	55	I/C dB
Selectivity Imag frequency	Wanted signal at -67dBm, modulated interferer at imagefrequency, 37 Byte BER=1E-3	28	I/C dB
Intermodulation	Wanted signal at 2402MHz, -64dBm, Two interferers at 2405 and 2408 MHz respectively, at the given power level, 37 Byte BER=1E-3	-18	dBm
Carrier Frequency Offset Tolerance		+/- 350	KHz
Sample Clock Offset Tolerance		+/- 120	ppm

**Table 35: RX 125Kbps GFSK**

## 7.4 RSSI Specifications

Parameter	Description	MIN	TYP	MAX	UNIT
RSSI Dynamic Range			70		dB
RSSI Accuracy	RSSI Accuracy Valid in range -100 to -30dBm		+/-2		dB
RSSI Resolution	Totally 7bit, from 0 to 127		1		dB
RSSI Period			8		us

**Table 36: RSSI specifications**

## 8 Glossary

Term	Description
AHB	Advanced High-performance Bus (ARM bus standard)
AHB-AP	DAP AHB Port for debug component access thru AHB bus
AMBA	Advanced Microcontroller Bus Architecture
AON	Always-on power domain
APB	Advanced Peripheral Bus (ARM bus standard)
APB-AP	DAP APB Port for debug component access thru APB bus
BROM	Boot ROM
DAP	Debug Access Port ( ARM bus standard)
ETM	Embedded trace module
FPU	Floating Point Unit
I2C	Inter-Integrated Circuit
I2S	Inter-IC Sound, Integrated Interchip Sound
ITM	Instrumentation Trace Macrocell Unit
JTAG	Joint Test Access Group (IEEE standard)
JTAG-AP	DAP's JTAG Access Port to access debug components
JTAG-DP	DAP's JTAG Debug Port used by external debugger
J&M	Jun and Marty LLC
MPU	Memory Protection Unit
NVIC	Nested vector Interrupt Controller
PCR	Power Clock Reset controller
POR	Power on reset, it is active low in this document
RFIF	APB peripheral to interface RF block
SWD	Serial Wire DAP (ARM bus standard)
SoC	System on chip
SPI	Serial Peripheral Interface
SRAM	Static Random Access memory
TWI	Two-Wire Interface
UART	Universal Asynchronous Receiver and Transmitter
WDT	Watchdog Timer

**Table 37: Glossary**

## 9 Ordering information

Part No.	Package	Packing	MOQ(PCS)
ST17H63AAQB	QFN48	Tray	260
	QFN48	Tape&Reel	2500
ST17H63MAQB	QFN48	Tray	260
	QFN48	Tape&Reel	2500

**Table 38: Ordering information**

# 10 Package dimensions

## 10.1 QFN48 package dimensions:

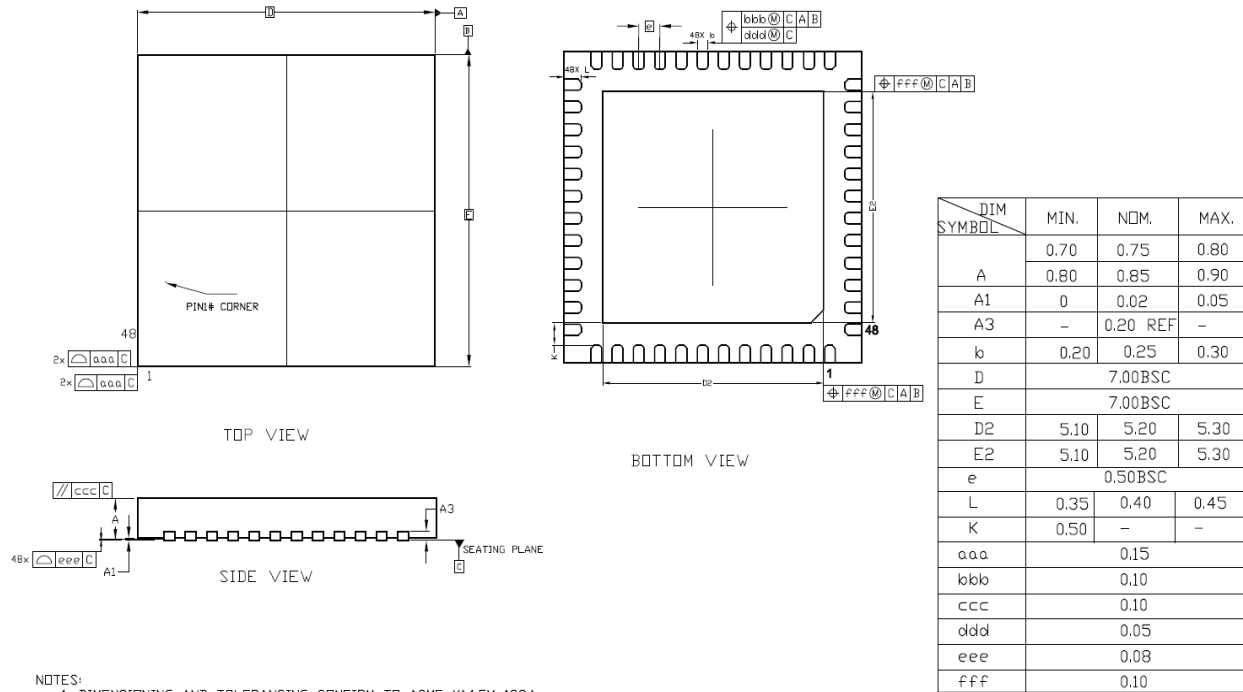

NOTES:  
1. DIMENSIONING AND TOLERANCING CONFIRM TO ASME Y14.5M-1994

Figure 17: QFN48 package dimensions

Note: dimensions are in mm, angels are in degree.

# 11 Sample Application and Layout Guide

## 11.1 Layout Guide

### 11.1.1 Placement

1. RF matching/Loop filter leading to antenna should be isolated from any other AC/DC signal as much as possible;
2. Xtal/OSC clock is a noise source to other circuits, keep clock trace as short as possible and away from any important area;
3. LDO's are sensitive and could be easily contaminated, care should be taken for the environment;
4. Antenna is the main RF radiation point, other important blocks should be shielded or away from this area.

#### RF traces

1. Define RF line width with given dielectric thickness (thickness of PCB dielectric layer to ground plain) to achieve 50ohm impedance; this is mainly for the RF line connecting to matching/loop filter and antenna.
2. Differential traces should be kept in the same length and component should be placed symmetrically;
3. Certain length of RF trace should be treated as part of RF matching.

### 11.1.2 Bypass Capacitor

1. Each VDD pin needs a bypass capacitor to release chip internal noise and block noise from power supply.

2. For power traces, bypass capacitors should be placed as close as possible to VDD pins.
3. Use one large and one small capacitor when the pin needs two capacitors. Typically the capacitance of the larger capacitor is about 100 times of that of the smaller one. The smaller capacitor usually has better quality factor than the larger one. Place the larger capacitor closer to the pin.
4. The capacitors of Loop filter need to have larger clearance to prevent EMC/EMI issue.
5. Ground via should be close to the Capacitor GND side, and away from strong signals.

### 11.1.3 Layer Definition

1. Normally 4 layer PCB is recommended.
2. RF trace must be on the surface layer, i.e. top layer or bottom.
3. The second layer of RF PCB must be "Ground" layer, for both signal ground and RF reference ground, DO NOT put any other trace or plane on second layer, otherwise "antenna effect" will complicate debug process.
4. Power plane generally is on the 3rd layer.
5. Bottom layer is for "signal" layer.
6. If two layer PCB is used, quality will degrade in general. More care needs to be taken. Try to maximize ground plane, avoid crossing of signal trace with other noise lines or VDD, shield critical signal line with ground plane, maximize bypass capacitor and number of ground vias.

### 11.1.4 Reference clock and trace

1. Oscillator signal trace is recommended to be on the 1<sup>st</sup> layer;
2. DO NOT have any trace around or across the reference clock (oscillator) trace.
3. Isolate the reference clock trace and oscillator by having more GND via around.
4. DO NOT have any other traces under the Oscillator.

### 11.1.5 Power line or plane

1. Whether to use power plain or power line depend on the required current, noise and layout condition. For RF chip, we generally suggest to use power line to bring power into IC pin. Line has parasitic inductance, which forms a low pass filter to reduce the noise traveling around PCB.
2. Add more conductive via on the current source, it will increase max current limit and reduce inductance of via.
3. Add some capacitor alone the power trace when power line travels a long distance.
4. DO NOT place power line or any plane under RF trace or oscillator and its clock trace, the strong clock or RF signal would travel with power line.

### 11.1.6 Ground Via

1. Ground Via must be as close to the ground pad of bypass capacitor as possible, too much distance between via and ground pad will reduce the effect of bypass capacitor.
2. Having as many ground via as possible.
3. Place ground via around RF trace, the RF trace should be shielded with via trail.